



BN Products-USA, LLC.

3450 Sabin Brown Road • Wickenburg, Arizona 85390
(800) 992-3833 • (928) 684-2813 • www.bnproducts.com



PROFESSIONAL PNEUMATIC NAILERS



AEROPRO Pneumatic Nailers Catalog 2017B

Tools That Grow Your Business



BN Products-USA, LLC.

3450 Sabin Brown Road • Wickenburg, Arizona 85390
 (800) 992-3833 • (928) 684-2813 • www.bnproducts.com



RHF9021 Non-Adjustable 21° Framing Nailer

- Large piston offers increased power (German steel)
- Contact and tripper safety system protects the operator
- A tool hook can be installed
- Sequential fire
- Package includes nailer, lubrication oil, Allen wrenches, eye protection and an operating manual

Nail Capacity	2 x 30 pieces
Fastener Length	2" to 3-1/2" (50-83mm)
Fastener Diameter	.113-.148" (2.87-3.76mm)
Magazine Angle	21° +/-1°
Collation	Plastic
Air Inlet & Operating Pressure	3/8" - 80-120 PSI (5.5-8.3 bar)
Dimensions	20-3/4 x 10-1/4 x 4-1/4" (530 x 260 x 108mm)
Weight	7.93 lbs. (3.96 kg)

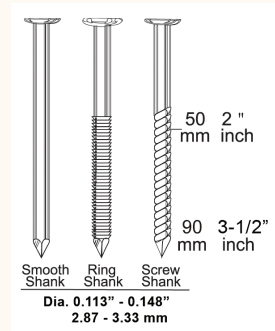

RHF9021-A Adjustable 21° Framing Nailer

- Adjustable depth of drive
- Large piston offers increased power (German steel)
- Contact and tripper safety system protects the operator
- A tool hook can be installed
- Single fire or sequential fire is selectable
- Package includes nailer, lubrication oil, Allen wrenches, eye protection and an operating manual

Nail Capacity	2 x 30 pieces
Fastener Length	2" to 3-1/2" (50-83mm)
Fastener Diameter	.113-.148" (2.87-3.76mm)
Magazine Angle	21° +/-1°
Collation	Plastic
Air Inlet & Operating Pressure	3/8" - 80-120 PSI (5.5-8.3 bar)
Dimensions	20-3/4 x 10-1/4 x 4-1/4" (530 x 260 x 108mm)
Weight	7.93 lbs. (3.96 kg)

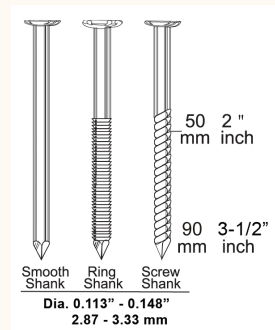



BN Products-USA, LLC.

3450 Sabin Brown Road • Wickenburg, Arizona 85390
 (800) 992-3833 • (928) 684-2813 • www.bnproducts.com

CN83 Coil Framing Nailer

- Lightweight and well balanced for easy operation
- Superior power with a hardened one-piece piston driver.
- Open nose design for easy extraction of jammed nail
- Tool free depth-of-drive adjustment for flush or counter-sink drive into various materials
- Hardened claw tip reduces wear and limits slippage
- Drives nails 1-3/4" to 3-1/4" x .131"
- Package includes nailer, lubrication oil, Allen wrenches, eye protection and an operating manual



Nail Capacity	225-300
Fastener Length	2" to 3-1/4" (50-83mm)
Fastener Diameter	Ø0.099-.131" (Ø 2.5-3.3mm)
Magazine Angle	15°
Collation	Wire
Air Inlet & Operating Pressure	3/8" (10mm) - 70-120 PSI (4.8-8.3 bar)
Dimensions	12.4 x 14.1 x 5.4" (315 x 359 x 136 mm)
Weight	8.75 lbs. (3.98 kg)

CN45RA Professional Heavy Duty Coil Roofing Nailer (3/4" to 1-3/4")

- Comfortable rubber grip for ease of use and control
- Firing Method: Contact trip
- Package includes nailer, lubrication oil, Allen wrenches, eye protection, and an operating manual
- Great for roofing and installation of fiber cement products

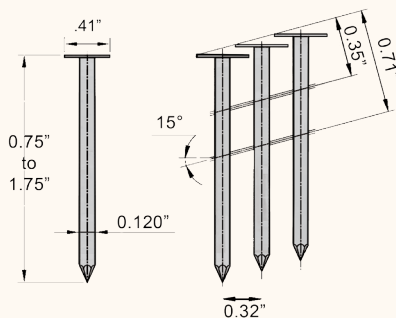

Nail Capacity	120
Fastener Length	3/4" to 1-3/4" (19-45mm)
Fastener Diameter	.098-.120" (2.5-3.05mm)
Magazine Angle	15°
Collation	Wire
Air Inlet & Operating Pressure	3/8" -- 80-120 PSI (5.5-8.3 bar)
Dimensions	11-1/8 x 10-5/8 x 5-1/8" (307 x 281 x 120 mm)
Weight	6.3 lbs. (2.86 kg)



BN Products-USA, LLC.

3450 Sabin Brown Road • Wickenburg, Arizona 85390
 (800) 992-3833 • (928) 684-2813 • www.bnproducts.com

TECO64 Metal Connector Nailer

- Compact design fits between 12" O.C. joists
- Low nail lockout prevents dry fires
- Advanced safety system prevents misfires
- Exposed nail tip design fires in the hole for faster, more precise nailing
- Applications include strapping, joist hangers, hurricane ties, rafter ties and connectors, post bases, caps and anchors
- Package includes nailer, lubrication oil, Allen wrenches, eye protection, carrying case and an operating manual

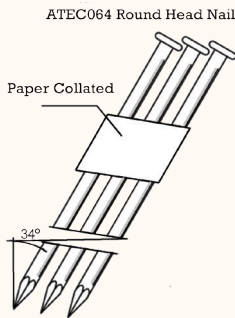

Nail Capacity	24
Fastener Length	1-1/2" (38mm)
Fastener Diameter	.131-.148" (3.33-3.76mm)
Magazine Angle	34°
Air Inlet & Operating Pressure	1/4" NPT -- 90-120 PSI (6.2-8.3 bar)
Dimensions	12-1/2" x 4-1/2" x 12-1/4" (319 x 113 x 309 mm)
Weight	6.83 lbs. (3.1 kg)



MSN90 Palm Nailer

- Magnetic nose hold nails in place
- Drives common nails from 1-3/4" to 3-1/4" (5d to 16d)
- Long-life German tool steel driver
- Applications include nailing joist hangers, hurricane ties, rafter ties and pole barns
- Package includes tool and instruction manual

Nail Capacity	1
Fastener Length	1-3/4"-3-1/4" (50-83mm) 5d-16d
Fastener Diameter	.109-.238" (2.77-6.05mm)
Magazine Angle	none
Collation	none
Air Inlet & Operating Pressure	1/4" NPT -- 70-100 PSI (5-7 bar)
Dimensions	4 x 3 x 4" (103 x 53 x 103 mm)
Weight	0.8 lbs. (0.35 kg)

