

BN Products-USA, LLC.
Construction
Products Catalog

Construction Products Catalog - 2015A



BN Products-USA, LLC.
3450 Sabin Brown Road
Wickenburg, Arizona 85390
(800) 992-3833 • (928) 684-2813
email: mail@bnproducts.com
Visit us on the Web: www.bnproducts.com

Quality Products Engineered with Intelligence and Imagination™

BNCE-20 The Cutting Edge Saw™



BEST OF SHOW!



A new design in a multipurpose cutting tool that can be used on all kinds of material found on the job. It can easily cut rebar, all-thread rod, locks, chain, EMT conduit, copper pipe, steel rods, steel tubing, and much more. This hand-held tool is light-weight and powered by 1100W motor that only pulls 9 amps using standard 120V/60Hz. It features a three position handle and has a no load speed of 2000 rpm. The capacity of the opening is .875" (23.62mm). This tool is ETL Listed and is excellent for cutting material flush with concrete or block. Prepaid freight on four + tool order to one location.

Voltage	120
Hertz	60
AMPS	9
Watts	1100
Blade Size	4.375" (110 mm)
Blade Type (2 ea.)	Tungsten Carbide Tipped
Blade Number of Teeth	24
Blade Kerf	1.6 mm
No Load RPM	2,000
Depth of Cut	.860" (21.8 mm)
Construction Type	DOUBLE INSULATED
Cord Type	18 AWG, 2 wire
Plug Type	U.S. POLARIZED 2-PRONG
Cord Length	10 ft. (3 m)
Length x Width	20.3" (515 mm) x 5.5" (140 mm)
Tool Height	3.9" (99 mm)
Net Tool Weight	7.6 lbs. (3.5 kg)



BNT-40 Automatic Rebar Tier

This electric rebar tying tool is lightweight and has a compact, easy to hold body. It runs on a 14.4V Lithium-Ion quick-charge battery that drives a brushless twisting motor.

On two No.6 rebars this tool will make over 2000 ties on a single charge. It comes with two batteries, a charger and four spools of wire ready to use. This tools will save you time and money.

Maximum Tying Diameter	40mm (2 #6 Bars)
Battery (75 min quick charge)	DC14.4 V
Weight	4.85 lbs. (2.2kg)
Turns per tie	3 Wraps
Ties per Coil	Up to 128
Ties per Charge	Up to 2,500
Wire Size	21 GA
Length of wire per tie	31" (780mm)
Dimensions (L) x (W) x (H)	11.22" x 3.94" x 11.65" (285mm x 100mm x 296mm)



Battery Powered Rebar Cutters

The **DCC-1618HL** and the **DCC-2018HL** cordless rebar cutters will safely and cleanly cut rebar up to 5/8" and 3/4" diameter grade 60 respectively. These self-contained electric/hydraulic units will also cut other items like chain, bolts, and rod. They can be used in rescue operations. It can cut in close proximity to a trapped victim and does not throw sparks. The cutting head on the DCC-1618HL rotates up to 345 degrees for use in vertical, horizontal, or difficult applications. Both have safety relief valves for retracting the piston and a cutting guard as standard features. These tools ship complete with (2) each 18 volt DC batteries, 30-60 minute fast battery charger, removable side handle, plastic carrying case, and a tool kit. We have available a tune-up kits for both models.

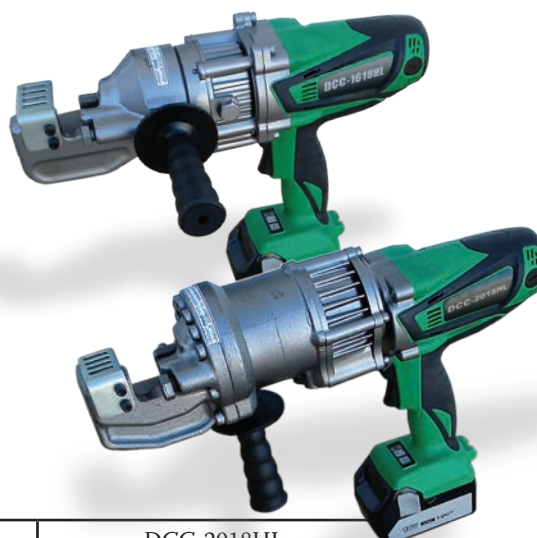

Model Number	DCC-1618HL	DCC-2018HL
Maximum Cutting Diameter	5/8" #5 Rebar (16mm) Grade 60	3/4" #6 Rebar (20mm) Grade 60
Cuts per battery /Cutting speed	75 cuts on full charge / 5 seconds	
Li-ion Battery	18 Volt DC, 3.0Ah	
Battery Charger	115 Volt 60 Hz Charger	
Tool Weight	14.75 lbs.(6.6 kg) with battery	21 lbs.(9.5 kg) with battery
Dimensions (w/o side handle) L x W x H	14.75"(374mm) x 4"(101mm) x 12"(240mm)	16.5"(419mm) x 4.25"(107mm) x 12"(304mm)



DC-16LZ Portable #5 Rebar Cutter



The DC-16LZ is a medium-duty rebar cutter that will safely, efficiently, and cleanly cut rebar up to #5 (5/8") diameter grade 60. This self-contained electric/hydraulic unit will also cut other items like chain, bolts and rod but is specifically designed for rebar. The DC-16LZ is intended for effortless medium-duty applications on vertical and horizontal rebar cutting applications. This tool would be a great asset for swimming pool, masonry, and ICF contractors. The DC-16LZ is a cold-cutting shear; unlike saws with abrasive blades and cutting torches, there are no sparks or flame. A safety relief valve for retracting the piston and a cutting guard are standard features. Ships complete in a durable plastic carrying case with hydraulic oil and a tool kit. Available Tune-up kit for DC-16LZ electric rebar cutter - TU16LZK.

Maximum Cutting Diameter	5/8" #5 Rebar (16mm) Grade 60
Cutting Speed / Pressure	2 Seconds / 13 Tons
Voltage / Amperage	115V 50/60Hz / 9 Amps
Tool Weight	15 lbs. (6.8 kg)
Dimensions L x W x H	14.8" (380mm) x 6.8" (175mm) x 4.1" (105mm)



Double Insulated

DC-16W Portable #5 Rebar Cutter

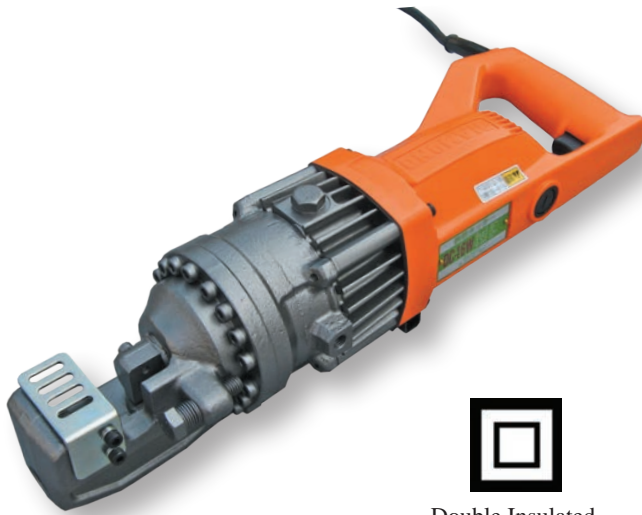

Double Insulated

The DC-16W portable heavy-duty rebar cutter will safely, efficiently, and cleanly cut rebar up to #5 (5/8") diameter grade 60. This self-contained electric/hydraulic unit will also cut other items like chain, bolts and rod but is specifically designed for rebar. The DC-16W cutter is designed for effortless vertical and horizontal cutting applications. The DC-16W is a cold-cutting shear unlike saws with abrasive blades and cutting torches. There are no sparks or flame and no trailing hoses to snare equipment or worker's feet. A safety relief valve for retracting the piston and a cutting guard are standard features. Ships complete in a durable plastic carrying case with a removable side handle, hydraulic oil and a tool kit. Available Tune-up kit for DC-16W electric rebar cutter - TU16K.

Maximum Cutting Diameter	5/8" #5 Rebar (16mm) Grade 60
Cutting Speed / Pressure	2.5 Seconds / 15 Tons
Voltage / Amperage	115V 50/60Hz / 10 amps
Tool Weight	17.6 lbs (8 kg)
Dimensions L x W x H (w/side handle)	18" (460mm) x 10.5" (270mm) x 4.5" (115mm)



DC-20WH Portable #6 Rebar Cutter

The DC-20WH portable heavy-duty rebar cutter will safely, efficiently, and cleanly cut rebar up to #6 (3/4") diameter grade 60. DIAMOND originated this concept in 1972; continuous development has led to higher output, lower weight, and even greater toughness and durability. The DC-20WH is a cold-cutting shear unlike saws with abrasive blades and cutting torches. There are no sparks or flame and no trailing hoses to snare equipment or worker's feet. Ideal for cutting epoxy-coated rebar. Fastest, safest, and most economical way to cut rebar on the job. A safety relief valve for retracting the piston and a cutting guard are standard features. Ships complete in a durable plastic carrying case with hydraulic oil and a tool kit. Available Tune-up kit for DC-20XH & WH electric rebar cutters - TU20K.



Maximum Cutting Diameter	3/4" #6 Rebar (19mm) Grade 60
Cutting Speed / Pressure	3 Seconds / 15 Tons
Voltage / Amperage	115V 50/60Hz / 10 amps
Tool Weight	25.4 lbs (11.5 kg)
Dimensions L x W x H	16" (410mm) x 4.3" (110mm) x 8.2" (210mm)

DC-25X Portable #8 Rebar Cutter

The DC-25X portable heavy-duty rebar cutter will safely, efficiently, and cleanly cut rebar up to #8 (1") diameter grade 60. The DC-25X cutter is ideal for a small fabrication shop. Because our rebar cutters feature a locking trigger switch, the cutter can be operated with a foot pedal switch and our GFI protected electrical outlet. There are no sparks or flame so it also works great on epoxy-coated rebar. It's the fastest, safest, and most economical way to cut rebar on the job. A safety relief valve for retracting the piston and a cutting guard are standard features. Ships complete in a steel carrying case with hydraulic oil and a tool kit. Available Tune-up kit for DC-25X electric rebar cutter - TU25K.



Maximum Cutting Diameter	1" #8 Rebar (25mm) Grade 60
Cutting Speed / Pressure	5 Seconds / 30 Tons
Voltage / Amperage	115V 50/60Hz / 12 amps
Tool Weight	49.6 lbs (22.5 kg)
Dimensions L x W x H	20" (515mm) x 5.9" (150mm) x 9.8" (250mm)



DC-32WH Portable #10 Rebar Cutter

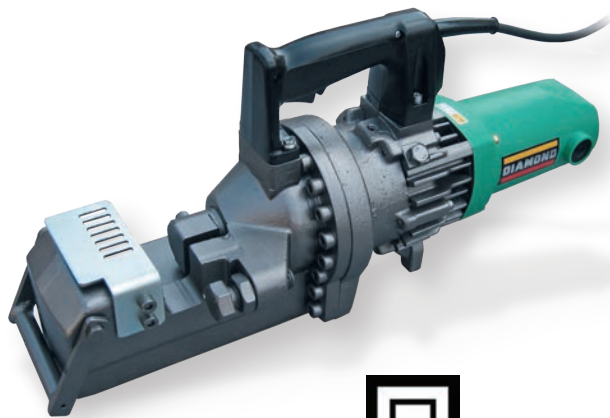

Double Insulated

The DC-32WH portable heavy-duty rebar cutter will safely, efficiently, and cleanly cut rebar up to #10 (1¼") diameter grade 60. The DC-32WH cutter is ideal for bridge and highway work, and in small rebar fabrication shops. This unit is available in combination with a DBD-32X bender on a stand. There are no sparks or flame so it also works great on epoxy-coated rebar. It's the fastest, safest, and most economical way to cut rebar on the job. A safety relief valve for retracting the piston and a cutting guard are standard features. Ships complete in a wooden carrying case with hydraulic oil and a tool kit. Available Tune-up kit for DC-32WH electric rebar cutter - TU32WHK

Maximum Cutting Diameter	1-1/4" #10 Rebar (32mm) - Grade 60
Cutting Speed / Pressure	7 Seconds / 45 Tons
Voltage / Amperage	115V 50/60Hz / 18 amps
Tool Weight	79 lbs (35.8 kg)
Dimensions L x W x H	23.1" (591mm) x 7" (180mm) x 10.6" (272mm)

HB-16W Portable #5 Rebar Bender



90 degree shoe and collar set

The HB-16W portable heavy-duty electric/hydraulic rebar bender helps save valuable man-hours by bending rebar up to 5/8" (#5) grade 60 from 0-135 degrees in-place at the job site. Other features include a double insulated electric motor and a removable bending guide for repeating the same angle bend. A standard 90 degree bending shoe and collar set make it simple to repeat 90 degree bends without a guide. The removable bending collar increases the bending radius and minimizes rebar breakage, especially on #5 grade 60. This portable electric/hydraulic rebar bender ships complete in a steel carrying case with hydraulic oil and a tool kit. Solves bending applications other tools can't even attempt.

Maximum Bending Diameter	5/8" #5 Rebar (16mm) - Grade 60
Bending Angle / Speed	0 - 135 degrees / 8 Seconds
Voltage/ Amperage	115V 50/60Hz / 10 amps
Tool Weight	33 lbs (15 kg)
Dimensions L x W x H	22.8" (584mm) x 7.6" (195mm) x 8" (205mm)



DBR-25WH Portable #8 Rebar Bender

The DBR-25WH is a portable heavy-duty electric/hydraulic rebar bender and straightener. It helps save valuable man-hours by cleanly and efficiently bending or straightening bent rebar. It functions as a simple 90-degree portable electric rebar bender. The interchangeable bending hook covers rebar diameters from #4 to #8 grade 60. Maximum pressure for bending and straightening ranges from 8.5 to 11 tons. It's portable and versatile enough to bend or straighten rebar in-place with its push/pull hydraulic capabilities. It will bend a 90-degree angle in only four seconds. The bending head also rotates 360 degrees. Ships complete in a wooden carrying case with hydraulic oil, a tool kit and two additional bending dies.



Small and large bending die set

Maximum Bending Diameter	1" #8 Rebar (25mm) Grade 60
Bending Angle	Up to 94 degrees (1/2") - up to 90 degrees (1")
Voltage / Amperage	115V 50/60Hz / 12 amps
Tool Weight	62.3 lbs (28 kg)
Dimensions L x W x H	25.75" (660mm) x 10.5" (270mm) x 7.8" (200mm)

DBD-16X Portable #5 Rebar Bender

The DBD-16X heavy-duty portable rebar bender helps save valuable man-hours by bending rebar up to #5 (5/8") grade 60 at the job site or in your shop. This strong electrical-mechanical bender has two preset angle locks for repeating the same angle bend. The dial-type angle selector can be set to accurately bend any angle from 0-180 degrees. Bends three each #3 rebar or two each #4 rebar or one each #5 rebar at one time. An emergency stop switch and two side lifting handles are standard features. Ships complete with set of (6) bending rollers in a steel carrying case, a tool kit, and a standard foot pedal control switch for hands-free bending.



Maximum Bending Diameter	5/8" (#5) Rebar (16mm) Grade 60
Bending Angle / Speed	Up to 180 degrees / 5 seconds
Voltage / Amperage	115V 50/60Hz / 10 amps
Tool Weight	90 lbs (40.8 kg)
Dimensions L x W x H	16.6" (425mm) x 12.5" (320mm) x 16.2" (415mm)



DBD-20X Portable #6 Rebar Bender

The DBD-20X heavy-duty portable rebar bender helps save valuable man-hours by bending rebar up to #6 (3/4") grade 60 at the job site or in your shop. This strong electrical-mechanical bender has two preset angle locks for repeating the same angle bend. The dial-type angle selector can be set to accurately bend any angle from 0-180 degrees. An emergency stop switch and two side lifting handles are standard features. The DBD-20X portable rebar bender comes complete with set of six bending rollers in a steel carrying case, a tool kit, and a standard foot pedal control switch for hands-free bending.



Maximum Bending Diameter	3/4" (#6) Rebar (19mm) Grade 60
Bending Angle / Speed	Up to 180 degrees / 7 seconds
Voltage / Amperage	115V 50/60Hz / 15 amps
Tool Weight	134.5 lbs (61 kg)
Dimensions L x W x H	16.4" (420mm) x 18" (462mm) x 16.2" (415mm)

DBD-25X Portable #7 Rebar Bender

The DBD-25X heavy-duty portable rebar bender helps save valuable man-hours by bending rebar up to #7 (7/8") grade 60 at the job site or in your shop. This strong electrical-mechanical bender has two preset angle locks for repeating the same angle bend. The lever-type angle selector can be set to accurately bend any angle from 0-180 degrees. An emergency stop switch and two lifting handles are standard features. The DBD-25X portable rebar bender comes complete with a set of six bending rollers in a steel carrying case, a tool kit, a bender cover, and a standard foot pedal control switch for hands-free bending.



Maximum Bending Diameter	7/8" (#7) Rebar (22mm) Grade 60
Bending Angle / Speed	Up to 180 degrees / 6 seconds
Voltage / Amperage	115V 50/60Hz / 12 amps
Tool Weight	190 lbs (86 kg)
Dimensions L x W x H	19" (490mm) x 21.5" (550mm) x 17.2" (440mm)



DBD-25H Portable #8 Rebar Bender

This heavy-duty portable bender helps to save valuable man-hours by effortlessly bending rebar up to #8 (1") grade 60 at job sites or in your shop. This electrical-mechanical bender has two preset angle locks for repeating the same angle bend. The lever-type angle selector can be set to accurately bend any angle from 0-180 degrees. The roller chart makes it easy to select the correct combination of rollers to achieve an inside bending diameter of six times the rebar diameter meeting ACI 318-05 specifications. An emergency stop switch and two lifting handles are standard features. The DBD-25H portable rebar bender comes complete with nine bending rollers in two steel carrying cases, a tool kit, a bender cover, and a standard foot pedal control switch for hands-free bending.



Maximum Bending Diameter	1" (#8) Rebar (25mm) Grade 60
Bending Angle / Speed	Up to 180 degrees / 9 seconds
Voltage / Amperage	115V 50/60Hz -15 amps
Tool Weight	210 lbs. (95 kg)
Dimensions L x W x H	21" (540mm) x 22.6" (580mm) x 17.2" (440mm)

DBD-32X Portable #9 Rebar Bender



The DBD-32X is a heavy-duty portable table-type bender. This unit is the largest 115 volt portable rebar bender available. This powerful electrical-driven mechanical unit will easily bend 1-1/8" grade 60 rebar 180 degrees in only 8 seconds. This fast and accurate bender is a valuable tool for small to medium size production shops. It comes standard with a hands-free foot pedal control switch and a complete bending radius roller set. An optional stand is also available.

Maximum Bending Diameter	1-1/8" (#9) Rebar (29mm) Grade 60
Bending Angle / Speed	Up to 180 degrees / 8 seconds
Voltage / Amperage	115V 50/60Hz / 12 amps
Tool Weight	397 lbs (180 kg)
Dimensions L x W x H	23" (590mm) x 24.2" (620mm) x 18.7" (480mm)



DBC-16H #5 Rebar Cutter/Bender

This DBC-16H portable combination rebar cutter and bender provides jobsite cutting and bending of rebar all in one tool. The unique design provides the operator the ability to cut and bend rebar for in-place rebar or stationary fabrication applications. Now you have the ability to cut and bend rebar protruding from a wall or column or just fabricate what you need on a table. Our powerful electric/hydraulic design is for heavy-duty #5 (16 mm) grade 60 rebar. It's fast and easy to use, there is no changing of attachments, bends rebar up to 180 degrees. A steel carrying case, tool kit, hydraulic oil and operations manual are included. All of our tools carry a one-year parts and labor warranty.



Cut / Bend Speed	3 seconds / 180 degree bend in 7 seconds
Bending Roller	2.42" (62 mm) Diameter (R 31)
Clearance (In-place) Cutting	1-3/4" (44.5 mm) from Surface
Clearance (In-place) Bending	4.5" (115 mm) from Surface
Rebar Capacity	Up to #5 (16mm) Grade 60
Power Supply	Electric motor 115v, 50/60 Hz -10 amps
Total Weight (kg)	40 lbs. (18.2) Tool Weight, 62lbs. (28.2) Shipping Weight
Tool Dimensions	25-1/8" L x 6-3/8" W x 8-5/8" H including lifting handles (cutter up)

DBC-20X Combination #6 Rebar Bender/Cutter

The DBC-20X combination bender and cutter is rated for 3/4" grade 60 rebar. This ultimate combination unit combines the very popular DC-20WH rebar cutter and the DBD-20X rebar bender together on a heavy-duty powder-coated skidded housing. The bender and cutter are simply plugged into the weather-protective electrical outlets, no hard wiring. The DC-20WH cutter can be removed and used in a portable application or secured in the stationary position with U-bolts and operated hands-free by a standard foot pedal switch. A toggle switch allows you to go from bending to cutting, the GFI plug is a standard safety feature. This unit is shipped fully assembled and includes a steel case with six bending rollers and a foot pedal control switch.



	DC-20WH Rebar Cutter		DBD-20X Rebar Bender	
Cut / Bend Speed	3 seconds		180 degree bend in 7 seconds	
Rebar Capacity	Grade 60	Up to #6 (3/4")	Grade 60	Up to #6 (3/4")
Power Supply	Electric motor 115V, 50/60 Hz –10 amp Cutter, 15 amp Bender			
Weight	212 lbs. Total Weight (96 kg), 25.4 lbs. Cutter, 134.5 lbs. Bender			
Dimensions	28" (711mm) L x 18" (457mm) W x 21.5" (546mm) H with lifting handles			



DBC-25H #8 Combination Rebar Bender/Cutter



The DC-25X rebar cutter can be removed and used in a portable application or secured in the stationary position with U-bolts and operated hands-free by the convenient foot pedal switch. This is a combination of the very popular DC-25X rebar cutter and our new DBD-25H rebar bender together on a heavy-duty powder-coated skidded housing. The bender meets all ACI 318-05 specifications. A toggle switch allows you to go from bending to cutting and both are operated hands-free with a foot pedal. The GFI plug is a standard safety feature. This combination unit is easy to maintain and is backed with a one-year parts and labor warranty. The unit is shipped fully assembled and includes two steel cases with nine bending rollers and a #1BR5130 foot pedal control switch.

	DC-25X Rebar Cutter	DBD-25H Rebar Bender
Cut / Bend Speed	5 seconds	180 degree bend in 9 seconds
Rebar Capacity	Grade 60 Up to #8 (1")	Grade 60 up to #8 (1")
Power Supply	Electric motor 115v, 50/60 Hz –12 amp Cutter, 15 amp Bender	
Total Weight	321 lbs. Total Weight, 49.6 lbs. Cutter, 210 lbs. Bender	
Dimensions	32.75" L x 28" W x 22.50" H including lifting handles	

DBC-2520 & DBC-2525 Combination Rebar Bender/Cutter

These are essential combination rebar bender and cutter units. They simply combine the very popular DBD-25X bender with the DC-20WH or DC-25X rebar cutter both together on a stationary stand. The main advantage to owning this versatile combination unit is that the rebar cutter can be simply removed and used in any portable application or locked into a stationary position and then operated by a standard foot pedal switch. The other advantage is production; the bender table is at the ideal working height and the DBD-25X bends rebar from 0 -180 degrees. The BCSE-25X combination stand joins the bender and cutter both together.



	DBC-2520	DBC-2525
Max. Cutting	#6 or ¾" Grade 60	#8 or 1" Grade 60
Max. Bending	#7 or 7/8" Grade 60	#7 or 7/8" Grade 60
Cutter Power	115 Volt 50 / 60 Hz -10 amps	115 Volt 50 / 60 Hz -12 amps
Bender Power	115 Volt 50 / 60 Hz -12 amps	115 Volt 50 / 60 Hz -12 amps
Total Weight	250 lbs. (113.5 kg)	274 lbs. (124.5 kg)
Dimensions	19.25" (490mm) L x 24.75" (629mm) W x 37.25 (946mm) H	



DBC-3225 & DBC-3232 Combination Rebar Bender/Cutter



These are essential combination rebar bender and cutter units. They simply combine the very popular DBD-32X bender with the DC-25X or DC-32WH rebar cutter both together on a stationary stand. The main advantage to owning this versatile combination unit is that the rebar cutter can be easily removed and used in any portable application or locked into a stationary position and then operated by a standard foot pedal switch. The other advantage is production; the bender table is at the ideal working height and the DBD-32X bends rebar from 0 -180 degrees. The BCSE-32X combination stand joins the bender and cutter both together.

	DBC-3225	DBC-3232
Max. Cutting	#8 or 1" Grade 60	#10 or 1-1/4" Grade 60
Max. Bending	#9 or 1-1/8" Grade 60	#9 or 1-1/8" Grade 60
Cutter Power	115 Volt 50 / 60 Hz -12 amps	115 Volt 50 / 60 Hz -18 amps
Bender Power	115 Volt 50 / 60 Hz -12 amps	115 Volt 50 / 60 Hz -12 amps
Total Weight	482 lbs. (219 kg)	511 lbs. (232 kg)
Dimensions	23" (590mm) L x 27" (686mm) W x 37.25 (946mm) H	

The BNHH-50 Hydro Hoe

Designed for mixing small batch, high-viscosity materials like concrete, mortar, and stucco.



This tool utilizes:

- A heavy-duty steel 3/4" pipe
- Industrial brass fittings for the hose connection
- An easy to use flow valve to control water and pressure
- A unique spray nozzle that delivers water to the head of the tool
- The mixing head has a double flow-through design
- The 48" handle incorporates two easy-comfort foam grips
- You can mix an 80 lbs concrete bag in less than a minute

Spray Nozzle



BNT-64 Rebar Tying Tool

The BNT-64 securely ties up to #10 (32mm) x #10 (32mm) rebars. The tool uses strong double tie wrap of 18 gauge (.081") galvanized wire in only 1.6 seconds a tie. Each wire spool ties 120-200 rebars. Wire spools are quickly and easily changed. The patented design allows you to easily change the handle from a vertical work position to a horizontal work position. The tool is shipped standard with the #32 wire guide for tying two #6 bars together. We also carry optional wire guides for three other rebar combinations including our #64 for tying #10 bars together. The tying tool comes complete with seven spools of tying wire, two batteries with a quick charger unit all in an impact resistant case.



Tool Weight	8.4 lbs (3.8 kg) w/ battery and wire spool
Shipping Weight	27 lbs (12.25 kg) complete package
Tool Dimensions L x W x H (mm)	25.74" (660mm) x 3.12" (80mm) x 7.02" (180mm) for horizontal work 22.62" (508mm) x 3.12" (80mm) x 11.31" (290mm) for vertical work
Wire Spool Length / Wire Types	(148 ft) 45 m per spool / Galvanized Wire
Wire Carton / Shipping Weight	40 wire spools per carton / 29 lbs. (13 kg)
Ties Per Battery Charge	750 ties per battery charge (4-5 wire spools)

Standard Wire Guide Installed	#32 wire guide ties maximum #6 x #6 rebars
Optional Wire Guides	#26 wire guide ties maximum #3 x #4 rebars • #51 wire guide ties maximum #8 x #8 rebars • #64 wire guide ties maximum #10 x #10 rebars
Battery Type (BN-12VNiMh)	Rechargeable Ni-Mh (nickel metal hydride)
Battery Voltage / Recharging Time	DC 12 Volt / Approx. 30 minutes
Battery Charger (#BN-12VChgr)	110-240 VAC, 50/60Hz

BNBC Bolt Cutters

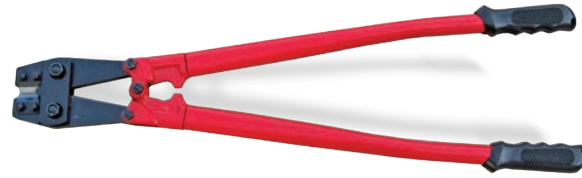
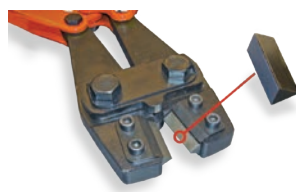

The new BN Products Bolt Cutter unlike similar tools of this kind has three durable cutting edges instead of just one that eventually wears out over a short period of time. The blades on this new model bolt cutter are made of special hardened alloy tool steel for a long lasting and more durable life. Along with having three durable edges, it comes with handles and grips that are designed for better mechanical leverage and control. This one-of-a-kind tool comes in three different sizes, 24", 30", and 36".

Product No.	Notes:
BNBC-24	24" Bolt Cutter Triple edge Cutting Blade Capacity: 5/16" (8mm)
BNBC-30	30" Bolt Cutter Triple edge Cutting Blade Capacity: 3/8" (9.5mm)
BNBC-36	36" Bolt Cutter Triple edge Cutting Blade Capacity: 7/16" (11mm)
RB-BNBC	Replacement Blade Set (Two blocks)



BNR7231A Drywall Sander

This Drywall and Plaster Sander is capable of sanding walls and ceilings. It provides you with a way to reach the entire wall from floor to ceiling. Just use the built-in extensions to change the length of the tool from 4 ft. to 7.2 ft. long. With extension you can easily reach up to 12 1/2 ft. It has a removable brush segment that allows the edge of the Sanding Paper to come right up to the wall edge. The tool can be folded in half to reduce the length of the tool and includes a carrying case. The motor is mounted on the sanding head to reduce the number of moving parts and provides a direct drive to the sanding head. Center and edge vacuum locations provide a large area of dust collection. Just mate the sander up with a vacuum to ensure a dust free working environment.



Model	BNR7231A
Power	600W
Voltage	120V/60HZ
No Load Speed	0-1000 rpm
Sanding Motion	Rotation
Sanding Pds (dia.)	9"
Abrasives (dia.)	9"
Connection for dust Extraction (dia.)	1.5"/1.25"
Weight	10.3 Lbs.

BN Products - USA

The BNR6169 Hand Held Paddle Mixer has a variable speed trigger with a lock-on button for continuous operation. It comes with a standard M14 paddle connection or 1/2" drill chuck for any mixing paddles. The rear D-handle rotates 360° and the tool comes with a 3-position removable side handle. Includes BNR010-120 paddle and carrying case.



Power	1050W / 9 amps / 1.4 Hp
Voltage	120V/60Hz
Number of Gears	1
No Load Speed	0-600 rpm
Drill Capacity	1/2" (13mm)
Motor Protective Type / Class	Double Insulated / II
Mixing Paddle (ø Max.)	4-3/4" (120mm)
Shipping Weight	13.25 lbs (6 Kg)

The BNR6400 Professional Mixer has ergonomically designed handles with a soft grip feature. The 2-speed power mixer motor incorporates a soft start feature with a variable speed control settings. Safety on/off switch also has a lock-on button for continuous operation. The tool uses a heavy-duty gearbox with a powerful high torque motor specially designed for mixing. Includes a BNR003-160 paddle, 1/2" drill chuck and M14 adapter

Power	1800W / 15 Amps / 2.4Hp
Voltage	120V/60Hz
Number of Gears	2
No Load Speed I	150 - 300 rpm
No Load Speed II	300 - 700 rpm
Motor Protective Type	Double Insulated
Mixing Paddles (ø Max.)	6-1/2" (160mm)
Shipping Weight	21 lbs (8.5 Kg)



The BNR6402K Professional Mixer has ergonomically designed handles with a soft grip feature. The 2-speed power mixer motor incorporates a soft start feature with a variable speed control settings. Safety on/off switch also has a lock-on button for continuous operation. The tool uses a heavy-duty gearbox with a powerful high torque motor specially designed for mixing. Includes our BNR008-120 mixing paddles



Power	1800W / 15Amps / 2.4 Hp
Voltage	120V/60Hz
Number of Gears	2
No Load Speed I	180 - 460 rpm
No Load Speed II	300 - 700 rpm
Motor Protective Type / Class	Double Insulated / II
Mixing Paddle (ø Max.)	4-3/4" (120mm)
Shipping Weight	19 lbs (8.5 Kg)

Paddles for the BN Power Mixers



BNRA0315	1/2" Drill Chuck
BNR001 - Specify Diameter	120 mm (4.75") or 140 mm (5.50") • Overall length: 60 cm (24") • Designed for plasters, adhesive mortars, mortars, tile adhesives and fillers, best for sticky and viscous materials. • Material Flow: Bottom to Top • Connection: M14 x 2 male threads
BNR002-57	Diameter: 57 mm (2.25") • Overall length: 13.5" • Designed for paints, lacquers, thin coatings, and ready-mix plaster. Use on BN6169 or drill. • Material Flow: Top to Bottom • Connection: 5/16" hex shank
BNR003- Specify Diameter	120 mm (4.75") or 140 mm (5.50") • Overall length: 60 cm (24") • Designed for concrete, mortars, plasters, heat-insulating plasters, and epoxy resin with sand, best for heavy and high viscosity materials. • Material Flow: Top to Bottom • Connection: M14 x 2 male threads
BNR004- Specify Diameter	120 mm (4.75") or 140 mm (5.50") • Overall length: 60 cm (24") • Designed for thinset, tile adhesive, grout, adhesive mortars, ready-mix mortars, and pointing mortars, and fillers, best for small volumes on high speed mixers. • Material Flow: Bottom to Top • Connection: M14 x 2 male threads
BNR005-120	Diameter: 120 mm (4.75") • Overall length: 60 cm (24") • Designed for plasters, adhesive mortars, tile adhesive and fillers, best for sticky and viscous materials. • Material Flow: Bottom to Top • Connection: M14 x 2 male threads
BNR006-100	Diameter: 100 mm (3.875") • Overall length: 60 cm (24") • Designed for paints, lacquers, glazings, primers, and paste, best for small volumes of low viscosity materials • Recommended to use on BNR6169. • Material Flow: Top to Bottom • Connection: M14 x 2 male threads



BNR008-120K Paddles sold in pairs left & right	Diameter: 120 mm (4.75") Overall length: 60 cm (24") • Designed for concrete, cement, mortars, and grouts with aggregate less than 3/8" diameter. Also for gypsum lime plaster, fibrated aluminum roof coatings and paints. Not for highly viscous materials. • Material Flow: Top to Bottom • Connection: 13 mm or 1/2" Hex Shank, for BN6402A mixer.
BNR009-Specify Diameter	120 mm (4.75") or 140 mm (5.50") • Overall length: 60 cm (24") • Designed for fillers, bitumen coatings, joint cement, epoxy-resin compounds, and grouting compounds, best for prevention of lump formation and lessens adding air into the mixture. Mixture flow is parallel. • Connection: M14 x 2 male threads
BNR010- Specify Diameter	120 mm (4.75") or 140 mm (5.50") • Overall length: 60 cm (24") • Designed for gypsum-lime plaster, fibrated aluminum roof coatings, and paints. This paddle can be disassembled in two pieces and fit into a carrying case. • Material Flow: Top to Bottom • Connection: M14 x 2 male thread

MBC-16B Manual Rebar Bender/Cutter

This tool has a longer handle and a cam mechanism that provides greater leverage when cutting and bending grade 60 rebar. It features an adjustable 2-1/2" (63.5mm) diameter bending roller and replaceable cutting jaws that incorporate two open slots with innovative shaped blades to prevent chipping. The sturdy frame design is firmly mounted on a 2" x 8" x 60" wooden board and is ready to use. Other features include a comfortable 12" long no-slip handle grip and a lifting chain and ring to make it easier to carry to and from the job site.



Model No.	MBC-16B
Cutting Capacity	#5 (5/8") (16 mm) rebar grade 60 (420 MPa)
Bending Capacity	#5 (5/8") (16 mm) rebar grade 60 (420 MPa)
Bending Capability	0 - 180°
Replacement Jaw Set	#MBC-16RJS - Weight: 7 lbs. (3.2 kg)
Shipping Weight	57 lbs. (26 kg) with wood board
Overall Dimensions	60.5" L x 7.5" W x 10" H
Warranty	6 months (includes parts and labor)



BN Portable Job-Site Generators



Our 4-cycle generators are compact, high performance power-houses. All of our models are air-cooled, gasoline driven units that are designed to supply electrical power to operate electrical loads on job sites, or in remote locations where utility power is unavailable or in place of a electric utilities due to a power outage. The Emission Control System for these generators are warranted for standards set by the Environmental Protection Agency and also the California Air Resources Board (CARB). The output receptacles include 12V, 8.3A DC, 120V 20A GFCI and, 120/240V AC 30A Twist Lock. Each unit comes complete with stand legs, solid rubber wheels and a pull handle for convenient mobility. All models are equipped with a key-start, low oil shut-off switch, a circuit breaker, and a fuel level gauge.

Available in Five models:

BNG2000	2000W rated power - pull start - carb certified - with GFCI plugs
BNG3000	3000W rated power - key electric start - CARB certified - with GFCI plugs
BNG5000	5000W rated power - key electric start - CARB certified - with GFCI plugs
BNG6500	6500W rated power - key electric start - CARB certified - with GFCI plugs
BNG7500	7500W rated power - key electric start - CARB certified - with GFCI plugs