



BN Products-USA, LLC.

3450 Sabin Brown Road • Wickenburg, Arizona 85390
(800) 992-3833 • (928) 684-2813 • www.bnproducts.com

Rebar Cutter Instruction & Parts Breakdown DC SERIES PORTABLE REBAR CUTTERS

DC-32WH DC-25X, DC-20WH,
DC-16W, DC-16LZ,
DCC-1618HL, DCC-2018HL



BN Products-USA, LLC.

3450 Sabin Brown Road
Wickenburg, Arizona 85390
(800) 992-3833 or (928) 684-2813
Fax: (928) 684-7041 • mail@bnproducts.com
www.bnproducts.com

IMPORTANT: READ THESE INSTRUCTIONS CAREFULLY BEFORE ATTEMPTING TO USE YOUR TOOL

Not knowing the proper operating procedures can lead to accidents. If you have any questions about any procedures, contact the nearest authorized distributor/agent or call BN Products-USA, LLC.
(800) 992-3833 or 928-684-2813.

CONTENTS

General Safety Precautions	3
Bleeding Instructions	3
Operation Instructions	3
Pre-use Checks	4
Parts and Specifications	4
Warm-up	4
Stopper Adjustment	4
Cutting	4
Points of Attention	4
Maintenance of Cutter Blocks	5
Cleaning	5
Oil-level Check	5
Oil Change	5
Bolt tightness	5
Carbon Brushes	5
General Safety Rules	6
Power Tool Care	6
DC-16LZ	7
DC-16W	8
DC-20WH	9
DC-25X	10
DC-32WH	11
DCC-1618HL	12
DCC-2018HL	14

**CUSTOMER SERVICE
TOLL -FREE NUMBER:
(800) 992-3833
WICKENBURG, ARIZONA:
(928) 684-2813**

GENERAL SAFETY PRECAUTIONS

Use rebar cutters on maximum Grade 60 steel reinforcing bars only. These tools are not to be used in cutting other kinds of metal or materials. Do not cut ungraded rebar.

IMPORTANT:

Do not attempt to cut rebar by locking the off/on switch to the on position. This locking procedure is to be used only to warm the tool in cold climates or used with our hands free electrical box and foot operated switch. This is a safety issue and may cause damage to your rebar cutter. Always pull the on/off switch by hand for each individual cut. A foot operated switch and special electrical box are available if you want to use these cutters as production tools. Contact your local distributor or BN Products

RESTRICT USE TO DESIGNATED MATERIALS

There is always a chance that the cut end may shoot out, especially if less than 30cm (1 foot) in length. Exceeding designated material specifications greatly increases this risk and will also damage the tool. Do not attempt to cut rebars harder, thicker or thinner than specified.

USE EYE PROTECTION

Wear safety goggles, safety glasses with side shields or a face shield when using cutter.

PROVIDE SAFETY BARRIERS

Erect safety screens to protect coworkers from possible flying ends. Place a safety screen under the rebar when working in high places.

EXERCISE PROPER CONTROL

Hold cutter firmly and maintain proper footing and balance. Do not overreach. When working in a high place, secure cutter to scaffolding with a safety rope. Check that power cord is not fouled and keep cord away from sharp edges and heat. Check that all adjusting wrenches have been removed before using cutter.

GUARD AGAINST ELECTRIC SHOCK

To avoid possible shock, do not handle cutter with wet hands or use cutter in the rain or damp places. Be aware of all power lines, electric circuits and other hazards that may be contacted, especially those that are below the surface or otherwise hidden from view. Never attempt to pick the tool up by use of the electric cord.

UNPLUG TOOL

Disconnect cutter from outlet when not in use and before cleaning, adjusting or servicing. Do not disconnect plug from outlet by pulling the cord. Always check that the switch lock is OFF before plugging in.

DO NOT CUT UNGRADED REBAR

MAINTAIN CUTTER WITH CARE

Inspect cutter before each application. Faulty or loose cutter blocks could result in personal injury. Keep handle dry, clean and free from oil and/or grease. Keep housing and piston free of dirt and iron filings. Check that no screws or bolts are loose or missing. Follow instructions for maintenance. Inspect switch, cord, plug and any extension cable at regular intervals. It is a good idea to inspect the housing for any cracks before operating.

DO NOT EXCEED MAXIMUM CUTTING PRESSURE BY ADDING TO OR MODIFYING THE HYDRAULIC PUMP.

BLEEDING YOUR PORTABLE REBAR CUTTER

You may have to bleed the hydraulics on your cutter if the tool runs unusually slow or doesn't have the pressure to cut normally. Do not run tool with low or no oil. For best results please follow these directions:

1. If piston is still moving, run the tool for 2 minutes to warm the oil inside. If the piston is not moving, add oil before warming up for 2 minutes.

2. When the oil is warm, run the piston out just before it returns and stop.

3. Remove the oil plug and top it off with oil.

4. Make a seal with your thumb over the oil plug opening.

5. Run the tool so that it makes a complete cycle.

6. When the piston is completely retracted in the open position, gently roll your thumb to let the unwanted air escape.

7. Repeat step #5 and #6 at least three times.

8. Add oil only when the piston is at least halfway out.

9. If you have to add additional oil, repeat #5 and #6.

10. Replace the oil plug and tighten it.

11. Make three or four cuts with rebar. The machine should now be working properly. Make sure that you observe exactly at what point the rebar is actually breaking.

12. Pinch a piece of rebar stopping just before it actually breaks.

13. Remove the oil plug again and top off the reserve one more time.

14. Replace the oil plug and tighten

15. The operation is now complete.

We recommend the following 20-wieght Non-Detergent Hydraulic Oils for use with our tools (anti-foam anti-abrasion): Tellus 68 (Shell), Rando HD 68 (Texaco) or Chevron AW 68 (Chevron). Hydraulic oil can also be ordered in quart containers from your Diamond Tool Distributor.

OPERATING INSTRUCTIONS

CAUTION: Indicates hazard that could result in minor personal injury and/or product damage.

CARE: Indicates hazard that will result in product damage.

PRE-USE CHECKS

1. Check oil level. (See Maintenance)
2. Check condition of cutter blocks and tightness of cutter block bolts. (See Maintenance) - CHECK FOR CRACKS IN HOUSING

CAUTION: *Using loose or cracked cutter blocks may result in injury to operator as well as damage to the tool.*

3. Check that the power source is appropriate to the cutter.

CARE: *If voltage is too high, the motor will burn out. If voltage is too low, insufficient power will be generated. Never use DC current.*

4. Check that power supply is properly grounded.

CAUTION: *Failure to ground power supply may result in electric shock to operator (DC-16LZ, DC-16W and DC-32WH have double-insulated motors and do not require grounding.)*

5. Check that cord is undamaged and that plug is not loose.

CAUTION: *Cut or abraded covering could result in a short and Electric shock to operator.*

6. If an extensions cable is to be used, make sure that it is undamaged and that it is the proper wire gauge thickness for

Length	110/115 50/60 Hz Cable Size (AWG)
Up to 15mm (50 ft.)	14
Up to 30mm (100 ft.)	12
Up to 45mm (150 ft.)	10

the length. See table below.

7. Before plugging in the tool, make sure that the switch lock is OFF.

CAUTION: *If switch lock is ON, cutter will start as soon as it is plugged in. To disengage lock, pull trigger-switch and press lock-button, which will pop out.*

WARM-UP

In cold weather you should warm up the tool unit for 30-60 seconds so that the hydraulic oil reaches the proper viscosity. Pull trigger-switch to extend piston and release when it has reached its full stroke. Repeat 15-20 times.

STOPPER BOLT ADJUSTMENT

THE STOPPER BOLT IS PROBABLY THE MOST IMPORTANT PART OF YOUR PORTABLE CUTTER...

The adjustable stopper functions to maintain the rebar in the correct position during cutting and must be properly set for each size of rebar before use.

1. Screw in stopper to provide sufficient clearance for rebar.
2. Insert rebar fully into U-shaped support. Make sure that rebar is resting on the base of the support.
3. Keeping rebar at right angles (90 degrees) to front cutter block, screw out stopper until it is just touching the rebar. Once set, the stopper needs no further adjustment while cutting rebar of the same diameter, but must be reset for a different size rebar.

CAUTION: *Failure to correctly set the stopper bolt will result in excessive wear of cutter blocks and may cause cut end to fly out. This will also lead to piston and cylinder damage.*

CUTTING

1. Insert rebar between stopper and front cutter block, making sure that it is properly seated in U-shaped support.
2. Pull trigger-switch and keep depressed while piston advances and rebar is cut. (If switch is released at an intermediate point, piston will stop.)
3. When cut is completed, release switch. Piston retracts automatically (Note that switch cannot be reactivated until piston has fully retracted.)

POINTS OF ATTENTION

1. Be especially careful when cutting off short lengths (30cm/12" or less) as the cut end tends to fly out.

CAUTION: *Flying ends are a hazard to all personnel in the vicinity. Erect safety screens.*

2. Do not cover air vents or operate the tool on dirt – use a plywood base under the rebar cutter to keep armature and fan clean

CARE: *If the vents are covered, the motor will overheat and may burn out.*

3. If hydraulic oil exceeds 70 degrees C (158 degrees F) in temperature, power will drop. Allow unit to cool before resuming operation. (Be particularly careful in summer, when the aluminum pump case heats up quicker.)
4. If a drop in power is observed and motor is unusually hot, check carbon-brushes. (See maintenance)
5. If piston should ever fail to retract completely, push rear cutter block backwards to manually retract piston or check under piston to remove and debris keeping the piston from retracting.

CAUTION: *Use a rebar or flat metal bar for this purpose. Never push cutter block with any part of the hand, even if gloved.*

NOTE: *Rebar cutters manufactured in after 2007 have a safety release valve for retracting the piston if it doesn't return to the start position. This is usually caused by cutting improperly seated rebar that becomes jammed between the cutting blocks. On these newer models simply rotate the Allen set screw a quarter turn to retract the piston. On the DC-20WH, see parts breakdown part #64 for location of this release valve.*

Once piston has been retracted, pull trigger-switch long enough to partially advance piston. Unplug unit. Check piston and housing for accumulated dirt and iron filings that may be jamming the piston. (See Maintenance) If, after cleaning, piston still does not automatically retract when fully extended, the piston itself may

be damaged. Return the unit to an authorized repair center or BN Products for repair.

MAINTENANCE ON CUTTER BLOCKS

Before using, always check that the two bolts on each cutter block are properly tightened. Using a loose block will result in damage to block and housing. Also check condition of cutter blocks. If either cutting edge is dull or chipped, remove retaining bolts and rotate both blocks so that two new edges come into use. Replace and tighten bolts. (Each block has four cutting edges.) When all four cutting

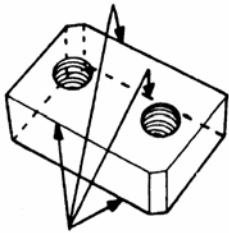

edges have been used or if either block is cracked or otherwise damaged, replace both blocks.

CAUTION: A loose or cracked block may result in injury to operator.

CLEANING

Clean your tool every day, preferably immediately after use.

CAUTION: Wear gloves to protect hands from metal splinters.

Do not use an air gun: blasting with air can cause metal filings and/or dust to get into eyes and respiratory system.

Disconnect the unit. Wipe or brush away all dirt and metal filings. Pay particular attention to the lower half of the piston, where dirt is more easily accumulated.

NEVER USE YOUR CUTTER TO CUT REBAR IN WET CONCRETE.

OIL-LEVEL CHECK

As the cutters are hydraulically operated, the oil-level must be checked at frequent intervals, preferably every day. Failure to maintain the oil at the proper level results in a drop in pressure and loss of cutting power.

CAUTION: Hydraulic oil is highly flammable. Keep away from sparks and naked flame. Do not smoke.

CAUTION: Hydraulic oil may cause inflammation of the eyes and skin. If ingested, it will cause diarrhea and vomiting. In case of eye contact, rinse in clean water for at least 15 minutes and consult a physician. In case of skin contact, wash thoroughly with soap and water. In case of ingestion, consult a physician immediately. Do not induce vomiting.

1. Oil should be warm but not hot. Warm up unit if cold.
2. Adjust stopper and make three or four cuts, noting exactly at what point the rebar is actually breaking.
3. Pinch a short piece of rebar, stopping just before it breaks off. Unplug unit from power source.
4. With partially severed rebar in place, oil-plug should be straight up. (If unit is hot, allow cooling down.)
5. Remove oil-plug and seal-washer (packing).

CAUTION: Never remove oil-plug when unit is hot or oil will spurt out.

6. Check that oil is level with bottom of plug hole (i.e. that pump case if full to the brim).

If oil level is too low, top up with 20-weight hydraulic oil with anti-foam and anti-abrasion properties (ISO viscosity grade VG46, e.g. Shell oil Tellus 68, Mobil oil DTE-25 or Esso Uni power SQ46).

7. After topping off, extract air from system. Gently tilt cutter lengthwise and return it to a level position. Top off again and tilt in the opposite direction. Repeat this process until all air has been extracted.

CARE: Cutter cannot function properly if oil contains air bubbles.

8. Replace seal washer (packing) and oil plug. Connect cutter to power source and completely sever rebar.

OIL-CHANGE

The hydraulic oil should be changed at least once a year, sooner if it appears dirty.

NOTE: Hydraulic oil should be warm before draining

1. Unplug unit from power source. Remove oil-plug and packing. Turn cutter over and drain oil into a suitable receptacle. When oil ceases to drain out, tilt unit to rear so that oil trapped in the piston housing can run out. When housing is empty, tilt unit in the opposite direction to empty the residue in the pump case.
2. With drain-hole uppermost, slowly fill the unit with fresh oil. Replace plug and lightly tighten. Connect unit to power source and advance piston two or three times. Unplug unit and remove oil-plug. Top off oil-level and replace plug.

3. Finally, follow procedure for oil-level check. (Steps 2-8)

NOTE: Dispose of hydraulic oil in accordance with local regulations. Do not pour into the sea, a river, a lake or drains.

BOLT TIGHTNESS

Once a week, or after every 500 cuts, check the tightness of all bolts; especially those bolts securing the housing to the cylinder. Loose bolts will result in a loss of power. Make sure that the bolts holding both cutter blocks are also tight

CARBON BRUSHES

Inspect the two carbon brushes at least once every two months. (Nominal brush life is 200 hours).

CARE: Worn brushes will result in power loss, cause the motor to run hot and irreparably damage the armature.

1. Disconnect unit.
2. Unscrew both brush caps and pull out carbon brushes.
3. Replace brushes if less than 6mm or 1/4" in length.

OVERHAUL

Return the unit to an authorized agent for overhaul at least once every two years, sooner if subjected to heavy use. Call (800) 992-3833

GENERAL SAFETY RULES

WARNING: Read all instructions. Failure to follow all instructions listed below may result in electric shock, fire and/or serious injury. The term “power tool” in all of the warnings listed below refers to your mains-operated (corded) power tool or battery-operated (cordless) power tool.

SAVE THESE INSTRUCTIONS WORK AREA SAFETY

Keep work area clean and well lit. Cluttered or dark areas invite accidents.

Do not operate power tools in explosive atmospheres, such as in the presence of flammable liquids, gases or dust. Power tools create sparks which may ignite the dust or fumes.

Keep children and bystanders away while operating a power tool. Distractions can cause you to lose control.

ELECTRICAL SAFETY

Power tool plugs must match the outlet. Never modify the plug in any way. Do not use any adapter plugs with earthed (grounded) power tools. Unmodified plugs and matching outlets will reduce risk of electric shock.

Avoid body contact with earthed or grounded surfaces such as pipes, radiators, ranges and refrigerators. There is an increased risk of electric shock if your body is earthed or grounded.

Do not expose power tools to rain or wet conditions. Water entering a power tool will increase the risk of electric shock.

Do not abuse the cord. Never use the cord for carrying, pulling or unplugging the power tool. Keep cord away from heat, oil sharp edges or moving parts. Damaged or entangled cords increase the risk of electric shock.

When operating a power tool outdoors, use an extension cord suitable to outdoor

use. Use a cord suitable for outdoor use reduces the risk of electric shock.

PERSONAL SAFETY

Stay alert, watch what you are doing and use common sense when operating a power tool. Do not use a power tool while you are tired or under the influence of drugs, alcohol or medication. A moment of inattention while operating power tools may result in serious personal injury.

Use safety equipment. Always wear eye protection. Safety equipment such as dust mask, non-skid safety shoes, hard hat, or hearing protection used for appropriate conditions will reduce personal injuries.

Avoid accidental starting. Ensure the switch is in the off-position before plugging in. Carrying power tools with your finger on the switch or plugging in power tools that have the switch on invites accidents.

Remove any adjusting key or wrench before turning the power tool on. A wrench or a key left attached to a rotating part of the power tool may result in personal injury.

Do not overreach. Keep proper footing and balance at all times. This enables better control of the power tool in unexpected situations. Dress properly. Do not wear loose clothing or jewelry. Keep your hair, clothing and gloves away from moving parts. Loose clothes, jewelry or long hair can be caught in moving parts.

If devices are provided for the connection of dust extraction and collection facilities, ensure these are connected and properly used. Use of these devices can reduce dust-related hazards.

POWER TOOL USE AND CARE

Do not force the power tool. Use the correct power tool for your application. The correct power tool will do the job better and safer at the rate for which it was designed.

Do not use the power tool if the switch does not turn it on and off. Any power tool that cannot be controlled with the switch is dangerous and must be repaired.

Disconnect the plug from the power source and/or the battery pack from the power tool before making any adjustments, changing accessories, or storing power tools. Such preventative safety measures reduce the risk of starting the power tool accidentally.

Store idle power tools out of the reach of children and do not allow persons unfamiliar with the power tools or these instructions to operate the power tool. Power tools are dangerous in the hands of untrained users.

Maintain power tools. Check for misalignment or binding or moving parts, breakage of parts and any other condition that may affect the power tools operation. If damaged, have the power tool repaired before use. Many accidents are caused by poorly maintained power tools.

Keep cutting tools sharp and clean. Properly maintained cutting tools with sharp cutting edges are less likely to bind and are easier to control.

Use the power tool, accessories and tool bits etc., in accordance with these instructions and in the manner intended for the particular type of power tool, taking into account the working conditions and the work to be performed. Use of the power tool for operations different from those intended could result in a hazardous situation.

SERVICE

Have your power tool serviced by a qualified repair person using only identical replacement parts. This will ensure that the safety of the power tool is maintained.

For a Service Repair Center nearest you please call (800)992-3833 or go on-line www.bnrebartools.com



BN Products USA, LLC
3450 Sabin Brown Road
Wickenburg, Arizona 85390
(800) 992-3833 or
(928) 684-2813
Fax: (928) 684-7041

DC-16LZ

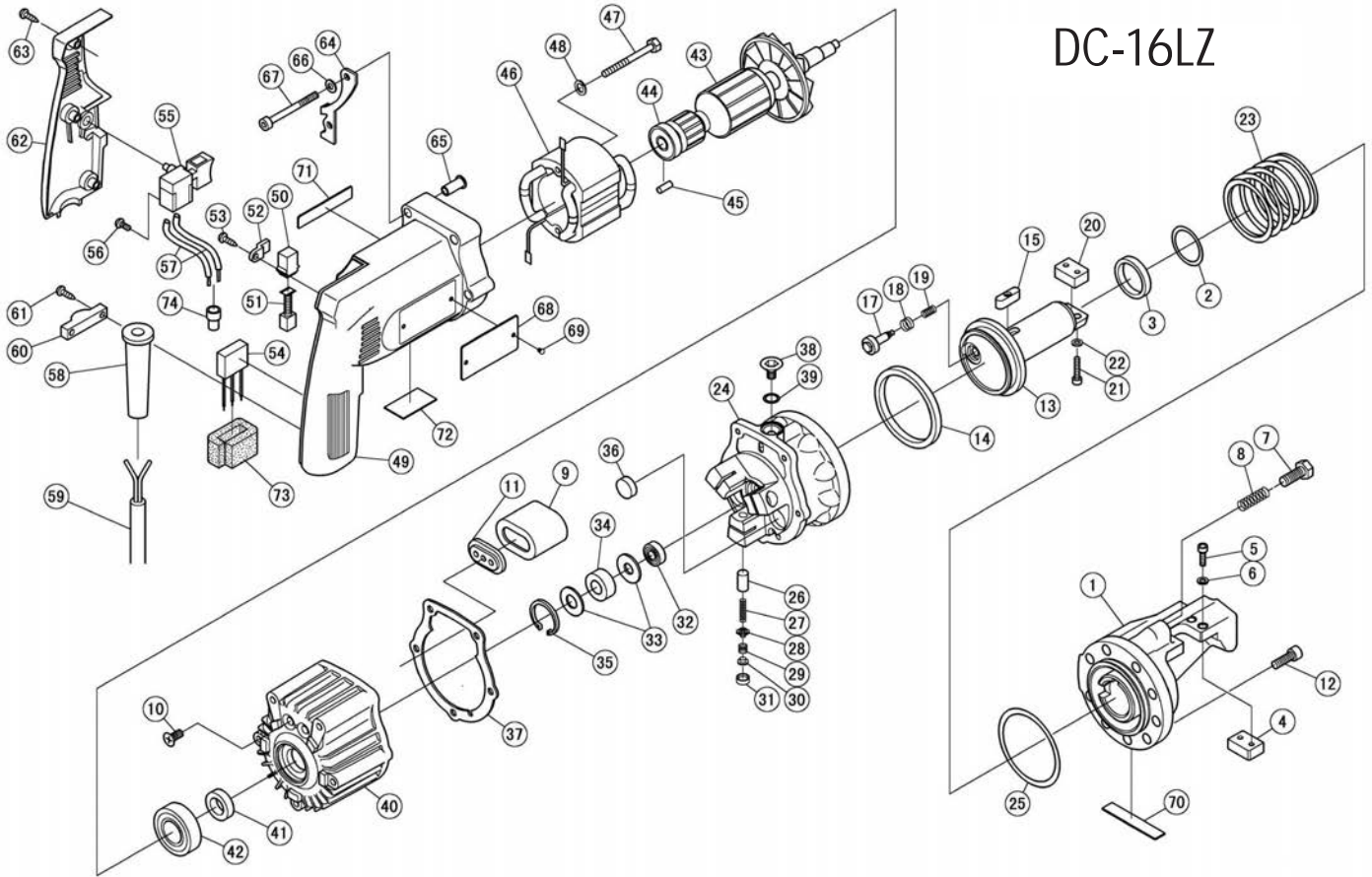

DC-16LZ Rebar Cutter		
1	1C2025700	HOUSING (DC-16LZ)
2	70RP30	O RING P30
3	1C16021	SEAL PACKING SKY30
4	RB-16LZ	CUTTER BLOCK SET
5	7CB05015	CAP BOLT M5XM15
6	7SW0005	SPRING WASHER M5
7	7B810025	STOPPER BOLT M10X25
8	1C4079400	LOCK SPRING
9	1C4078900	AIR BAG
10	7ST0612	TAPPING SCREW (+) 6x12
11	1C4079000	AIRBAG NUT
12	7CB08022	CAP BOLT M8X22
13	1C3039700	PISTON
14	7FU0825L0	SEAL PACKING OSI66-56-6
15	1C4079701	PISTON KEY 7X8X24
17	1CL0123	RETURN VALVE
18	1CL0143	RETURN VALVE SPRING
19	1C1922	VALVE END SPRING
20	SEE 6	SEE 6
21	7CB05015	CAP BOLT M5X15
22	7SW0005	SPRING WASHER M5
23	1CL016	RETURN SPRING
24	1C2025600	CYLINDER

25	70RG60	O RING
26	1C1971	RAM
27	1C1972	RAM RETURN SPRING
28	1C1973	DELIVERY VALVE
29	1C1331	DELIVERY VALVE SPRING
30	1C13352	SPRING GUIDE
31	1C13292	PUMP HEAD SEAL
32	3P1030	BEARING 608
33	1C1325	BEARING GUIDE
34	1C1340	NEEDLE BEARING
35	1C1326	SNAP RING H27
36	3P1044	MAGNET FILTER
37	1C4079300	PUMP CASE PACKING
38	7SB0812	OIL PLUG M8x12
39	70RP10	O RING P-10
40	1C2025800	PUMP CASE
41	1C1342	OIL SEAL
42	76002VV	BALL BEARING 6002VV
43	3V0001E	ARMATURE WITH CAM
44	7608VV	BALL BEARING
45	1CL001P	BEARING LOCK
46	3V0001D	STATOR COIL
47	7HT04070	TAPPING SCREW D4X70
48	7SW0004	SPRING WASHER M4
49	3V0001K	MOTOR HOUSING

50	1CL001C	BRUSH HOLDER
51	1C1361A	CARBON BRUSH SET
52	3V0001P	HOLDER PIECE
53	7NS04016	TAPPING SCREW D4X16
54	3V0001W	CONDENSER
55	4V0001N	SWITCH
56	7WB035006	SCREW M3.5X6
57	3V0001R	LEAD WIRE
58	3V0001Z	CORD ARMER
59	4V001V	CORD SET
60	1CL001Q	CORD CLIP
61	7FNS04016	TAPPING SCREW D4X16
62	3V0001L	HANDLE COVER
63	7WNS04020	TAPPING SCREW D4X20
64	3V0001V	FOOT
65	3V0001S	SLEEVE
66	7PW0005	PLATE WASHER M5
67	7CB05075	CAP BOLT M5X75
68		NAME PLATE
69	7R020032	RIVET
73	1CL001R	SUPPORT B
74	1CL001M	CONNECTOR
75	1DBR2943	STEEL BALL 5/32

DC-16W

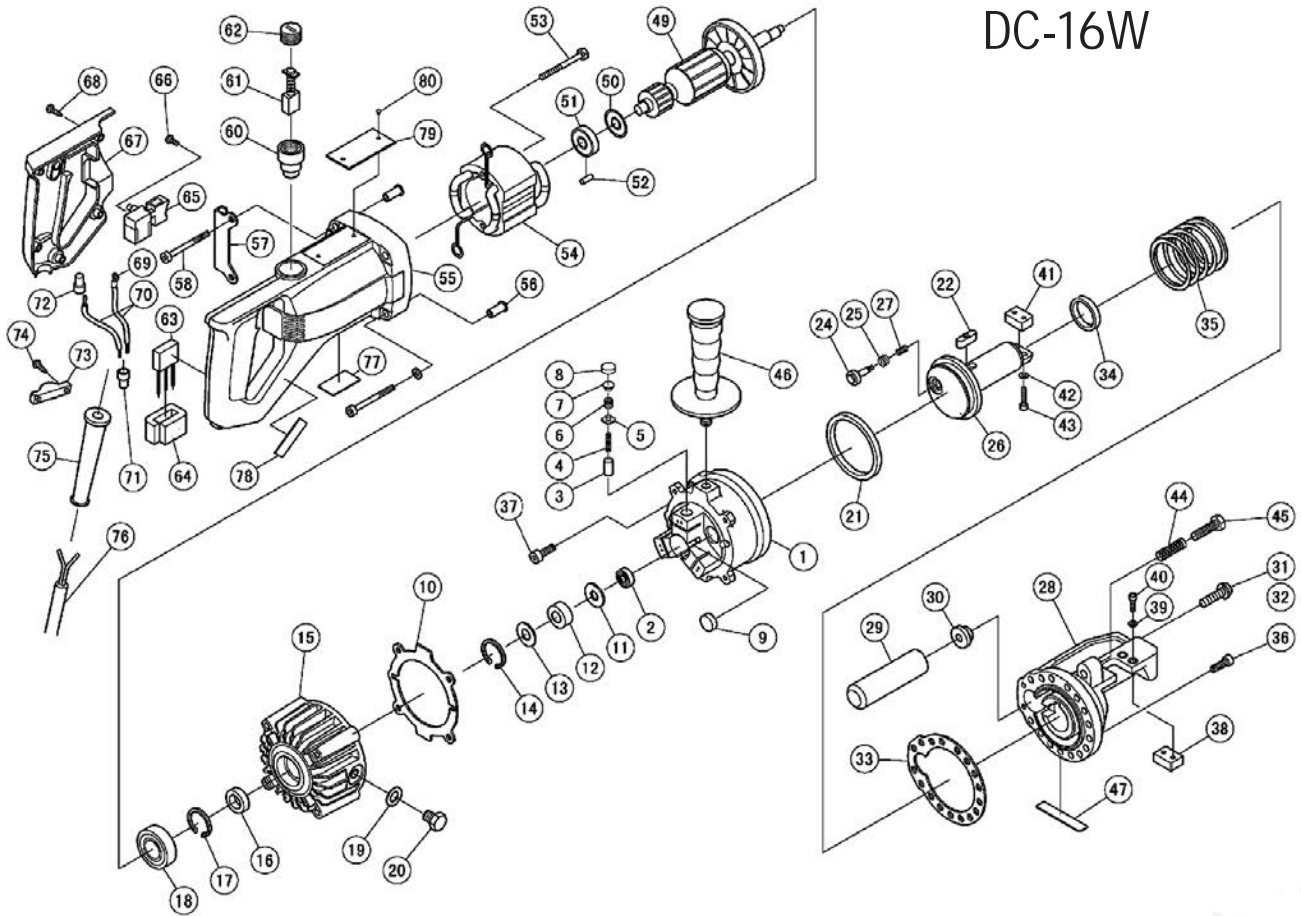

DC-16W Rebar Cutter

1	1CW0001	CYLINDER (DC 16X)
2	1CW0003	BALL BEARING 698
3	1C1327	RAM
4	1C1330	RAM RETURN SPRING
5	1C13281	DELIVERY VALVE
6	1C1331	DELIVERY VALVE SPRING
7	1C13352	SPRING GUIDE
8	1C13292	PUMP HEAD SEAL
9	3P1044	MAGNET FILTER
10	1C1615	PUMP CASE PACKING
11	1C1325	BEARING GUIDE
12	1C1340	NEEDLE BEARING
13	1C1325	BEARING GUIDE
14	1C1326	SNAP RING H27
15	4V0001A	PUMP CASE
16	7SD15257	OIL SEAL
17	7HR26	SNAP RING H26
18	76002VV	BALL BEARING 6002VV
19	1C1305	SEAL WASHER
20	1C1304	OIL PLUG M10x15
21	1C1604	SEAL PACKING
22	1C16182	PISTON KEY
24	1C1319	RETURN VALVE
25	1CL0143	RETURN VALVE SPRING
26	1C16172	PISTON
27	1C1323	VALVE END SPRING

28	1C16012	HOUSING
29	1C1616	AIR BAG
30	1C1620	AIR BAG NUT
31	7SW0008	SPRING WASHER M8
32	1CM2-28	AIR BAG SET BOLT
33	1C16142	CYLINDER PACKING
34	1C16021	SEAL PACKING SKY30
35	1C16052	RETURN SPRING
36	7CB06020	CAP BOLT M6x20
37	7CB06020	CAP BOLT M6x20
38	RB-16X	CUTTER BLOCK SET
39	7SW0005	SPRING WASHER M5
40	7CB05018	CAP BOLT M5x18
41	SEE 38	SEE 38
42	7GW0005	WASHER M5
43	7CB05015	CAP BOLT M5x15
44	1C1603	LOCK SPRING
45	7B810040	STOPPER BOLT M10X40
46	1C1627	SIDE HANDLE
47	7DN167	STICKER
49	4V0001B	ARMATURE WITH CAM
50	4V0001J	DUST SEAL (A)
51	7608VV	BALL BEARING 608VV
52	4V0001G	BEARING LOCK
53	7WNS05060	TAPPING SCREW D5x60
54	4V0001C	STATOR COIL
55	4V0001H	MOTOR HOUSING

56	4V0001K	SLEEVE
57	4V0001L	FOOT
58	7CB05080	CAP BOLT M5x80
59	7SS04005	SET SCREW M4x5
60	4V0001D	BRUSH HOLDER
61	1C1961A	CARBON BRUSH SET
62	4V0001E	BRUSH CAP
63	4V0001P	CONDENSER
64	4V0001Q	SUPPORT (B)
65	4V0001N	SWITCH
66	7WB035006	SWITCH BOLT M3.5X6
67	4V0001M	SWITCH COVER
68	7WNS04020	TAPPING SCREW D4X20
69	4V0001S	TERMINAL
70	4V0001T	LEAD WIRE
71	4V0001U	CONNECTOR 50091
72	4V0001W	CONNECTOR 50092
73	4V0001R	CORD CLIP
74	7FNS04016	TAPPING SCREW D4X16
75	4V0001X	CORD ARMER
76	4V0001V	CORD SET
77	7DN018	STICKER
78	7DN121	STICKER
79	7DN202	NAME PLATE
80	7R020032	RIVET

DC-20WH

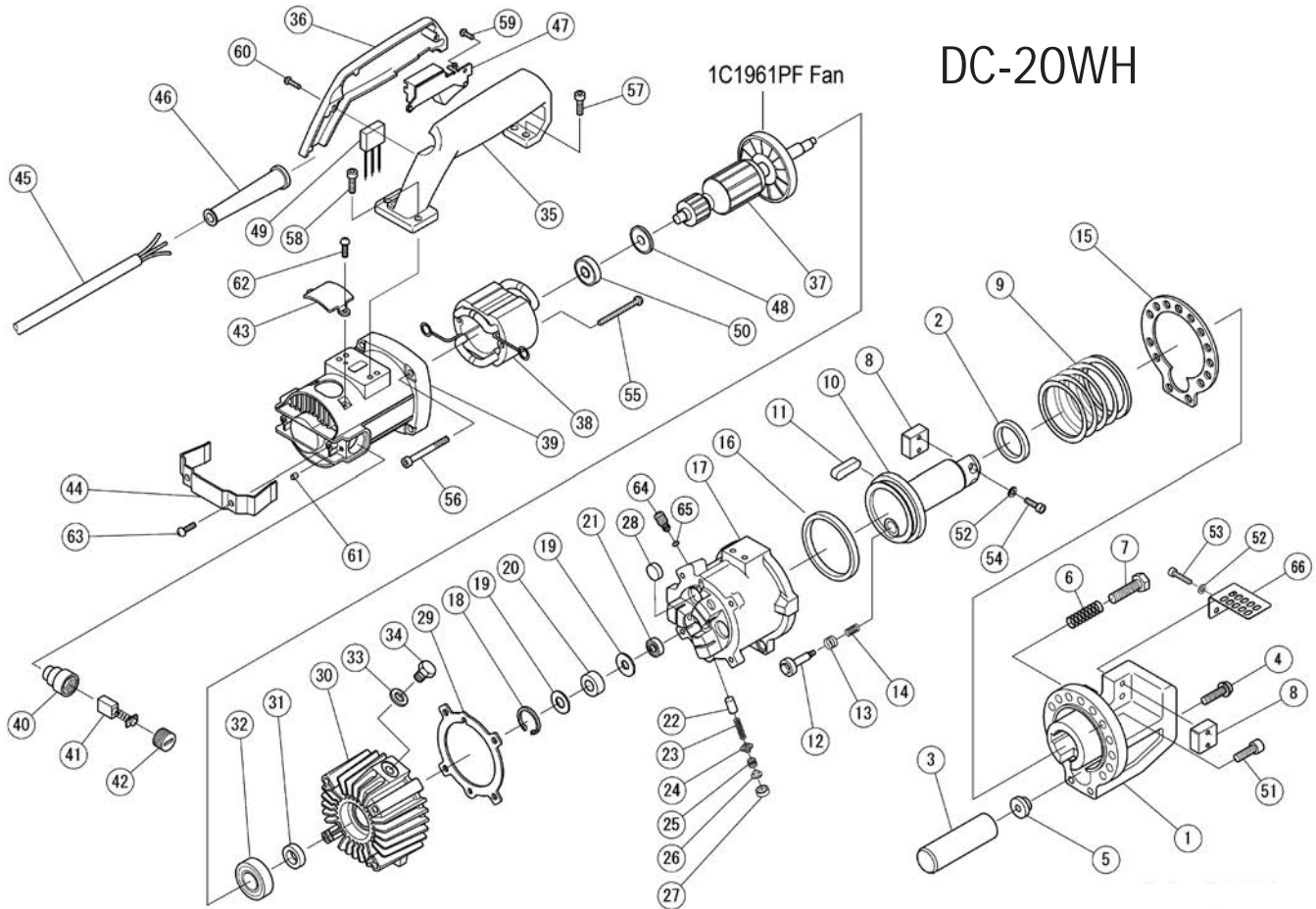

DC-20WH Rebar Cutter		
No.	Part No.	Part Name
1	1CM20012	HOUSING
2	1CM2002	SEAL PACKING SKY35
3	1C1958	AIR BAG
4	1CM2028	AIR BAG SET BOLT
5	1CM2027	AIR BAG NUT
6	1C1603	LOCK SPRING
7	7B10038	STOPPER BOLT M10X38
8	RB-20XH	CUTTER BLOCK SET
9	1C1920	RETURN SPRING
10	1C19171	PISTON
11	1C1936	PISTON KEY
12	1C1319	RETURN VALVE
13	1C1921	RETURN VALVE SPRING
14	1C1922	VALVE END SPRING
15	1CM2025	CYLINDER PACKING
16	1C1918	SEAL PACKING
17	1C2061500	CYLINDER
18	1C1326	SNAP RING H27
19	1C1325	BEARING GUIDE
20	1C1340	NEEDLE BEARING
21	1CW0003	BALL BEARING 698
22	1C1327	RAM

No.	Part No.	Part Name
23	1C1330	RAM RETURN SPRING
24	1C13281	DELIVERY VALVE
25	1C1331	DELIVERY VALVE SPRING
26	1C13352	SPRING GUIDE
27	1C13292	PUMP HEAD SEAL
28	3P1044	MAGNET FILTER
29	1C1951G	PUMP CASE PACKING
30	1C2059900	PUMP CASE
31	1C1342	OIL SEAL SC15-25-7
32	1C1941	BALL BEARING 6004VV
33	1C1305	SEAL WASHER WF10
34	1C1304	OIL PLUG M10X15
35	1C1944B/C	MAIN HANDLE
36	1C1946	SWITCH COVER
37	1C19612E	ARMATURE ASS'Y
38	1C1961D	STATOR COIL
39	1C1961K	MOTOR HOUSING
40	1C1961J	BRUSH HOLDER
41	1C1961A	CARBON BRUSH SET
42	1C1961H	BRUSH CAP
43	1C1961SC	SIDE COVER
44	1C1961TC	TAIL COVER

No.	Part No.	Part Name
45	1C1961F	CORD SET
46	1C1961I	CORD ARMER
47	1C1961B	SWITCH
49	1C1961L	CONDENSER
50	1C1961M	BALL BEARING 6000VV
51	1C1912	CAP BOLT M8X25
52	1C1311W	SPRING WASHER M5
53	1C1311B	CAP BOLT M5X25
54	1C1313	CAP BOLT M5X18
55	7P205055	PAN HEAD BOLT M5X55
56	1C1949	CAP BOLT M6X90
57	1BR5092	CAP BOLT M6X16
58	1C1945	CAP BOLT M6X18
59	7PB04008	PAN HEAD BOLT M4X8
60	1C1947	PAN HEAD BOLT M4X15
61	7SS05008	SET SCREW M5X8
62	7PB04008	PAN HEAD BOLT M4X8
63	7PB05010	PAN HEAD BOLT M5X10
64	1C4160601	RELEASE VALVE
65	7ORS4	O RING
66	1C4195900	CUTTER GUARD

DC-25X

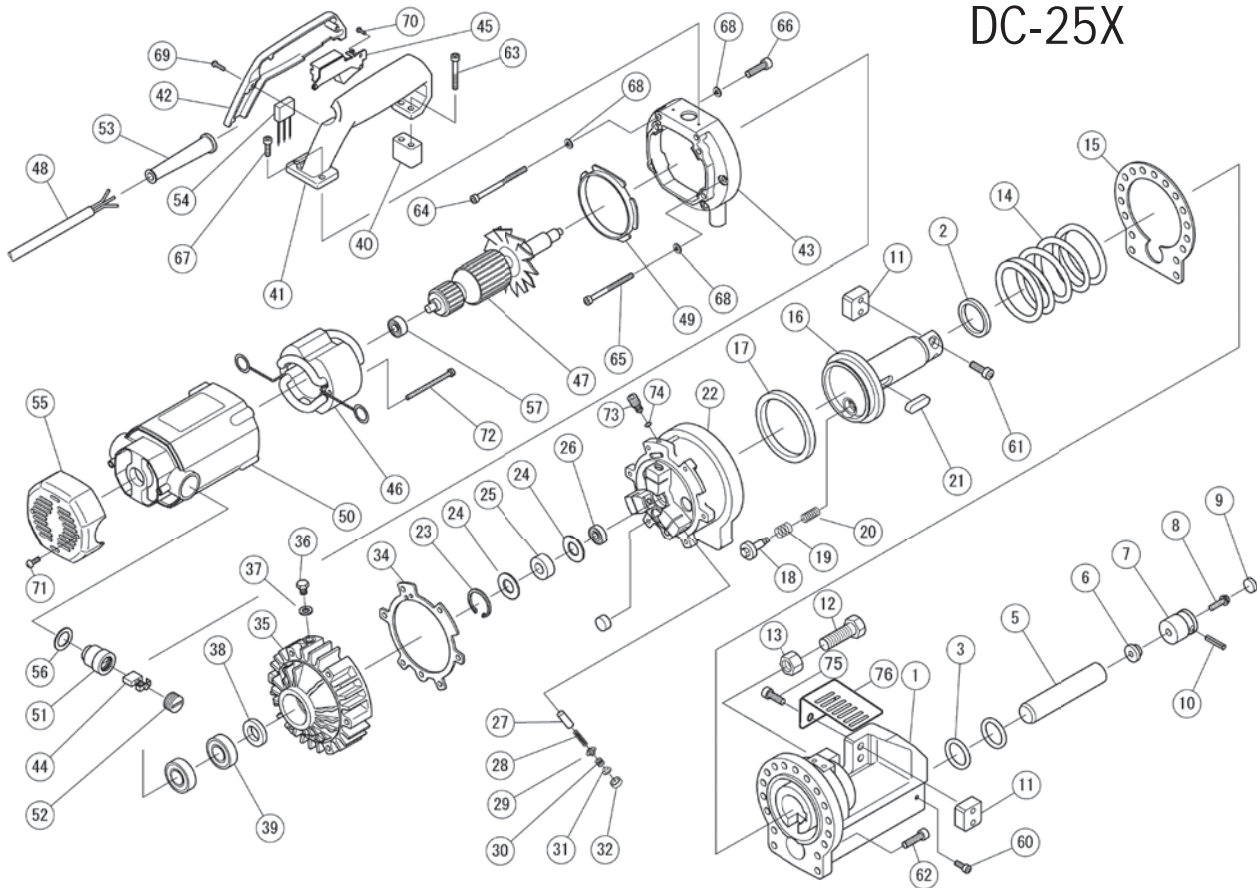

DC-25X Rebar Cutter		
No.	Part No.	Part Name
1	1C2601B	HOUSING
2	1C2602	SEAL PACKING
3	70RP32	O RING P32
5	1C2570	AIR BAG
6	1CM2027	AIR BAG NUT
7	1C2620B	HOUSING CAP
8	1CM2028	AIR BAG SET BOLT
9	1C1505	AIR FILTER
10	7SP06030	SPRING PIN D6X30
11	RB-25X	CUTTER BLOCK SET
12	7B16050	S BOLT M16X50
13	7N8016	STOPPER NUT M16
14	1C2607	RETURN SPRING
15	1C2614	CYLINDER PACKING
16	1C2604	PISTON
17	1C2518	SEAL PACKING
18	1C2519	RETURN VALVE
19	1C2521	R VALVE SPRING
20	1C2522	VALVE END SPRING
21	1C2605	PISTON KEY
22	1C1024200	CYLINDER
23	1C2526	SNAP RING H35
24	1C2525	BEARING GUIDE
25	1C2534	NEEDLE BEARING
26	1C2609	BALL BEARING 609

No.	Part No.	Part Name
27	1C2610	RAM
28	1C1330	R RETURN SPRING
29	1C13281	DELIVERY VALVE
30	1C1331	D VALVE SPRING
31	1C13352	SPRING GUIDE
32	1C13292	PUMP HEAD SEAL
33	3P1044	MAGNET FILTER
34	1C2615	PUMP CASE PACKING
35	1C25398	PUMP CASE
36	1C1304	OIL PLUG M10X15
37	1C1305	SEAL WASHER WF10
38	1C2542	OIL SEAL SC20-35-8
39	1C1941	BEARING 6004VV
40	1C2616	HANDLE PRESS
41	1C1944B/C	MAIN HANDLE
42	1C1946	SWITCH COVER
43	1C2611	CASE COVER
44	1C2612A	CARBON BRUSH SET
45	1C1961B	SWITCH
46	1C2612B	STATOR COIL
47	1C2612C	ARMATURE
48	1C1961F	CORD
49	1C2612D	FAN COVER
50	1C2612E	MOTOR HOUSING
51	1C2612F	BRUSH HOLDER

No.	Part No.	Part Name
52	1C2612G	BRUSH CAP
53	1C1961I	CORD ARMER
54	1C2612H	CONDENSER
55	1C2612I	MOTOR COVER
56	7956683	STOP PLATE
57	1C2612J	BALL BEARING 6200VV
60	1BR5092	CAP BOLT M6×16
61	1C1912	CAP BOLT W/WASHER
62	1C1911B	CAP BOLT M8×30
63	7CB06045	CAP BOLT M6×45
64	1C1949	CAP BOLT M6×90
65	7CB06075	CAP BOLT M6×75
66	7CB06035	CAP BOLT M6×35
67	1C1945	CAP BOLT M6×18
68	7SW006	SPRING WASHER
69	1C1947	P H BOLT M4X15
70	7PB04008	P H BOLT M4X8
71	7PSW05012	P H BOLT W/ WASHER
72	7PB05065	P H BOLT M5×65
73	1C4160601	RELEASE VALVE
74	7ORS4	O RING
75	7CGW08030	CAP BOLT W/WASHER
76	1C4199800	CUTTER GUARD

DC-32WH

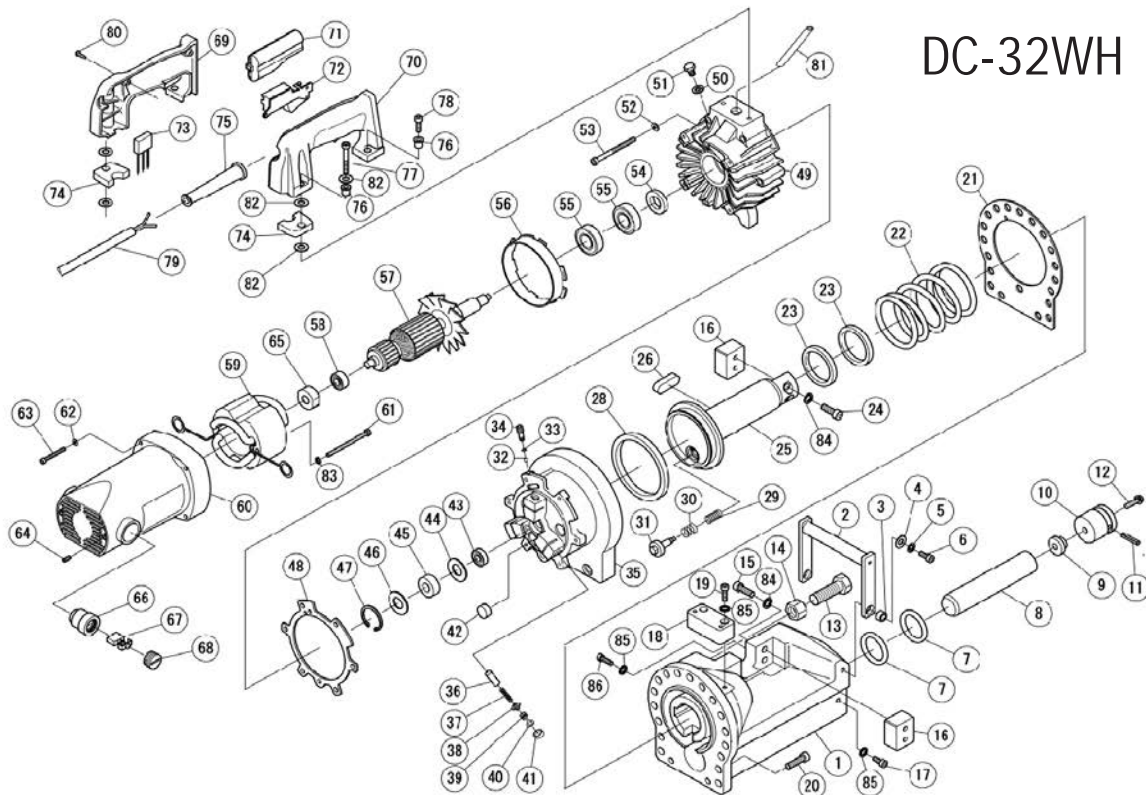

DC-32WH Rebar Cutter		
1	1C1022601	Housing (DC-32WH)
2	1C4172100	Sub handle
3	1C4172000	Collar
4	7PW0008	P. Washer M8
5	7SW0008	S. Washer M8
6	7B08020	Cap bolt M8x20
7	7ORP40	O ring P40
8	1C3258	Air bag
9	1C4171401	Air bag nut
10	1C4171601	Housing cap
11	7SP06036	Spring pin
12	1CM2028	Set bolt
13	7B11T20060	Bolt(11T) M20x60
14	7N11T0020	Nut(11T) M20-P2.5
15	7CB08035	Cap bolt M8x35
16	RB-32WH	Cutter blocks
17	1C1911B	Cap bolt M8x30
18	1C4171700	Handle spacer
19	7CB06025	Cap bolt M6x25
20	7CB10030	Cap bolt M10x30
21	1C3093600	Cylinder packing
22	1C4171900	Return spring
23	7CU0567KO	Seal packing USH45-55-6
24	1C1911B	Cap bolt M8x30
25	1C2056500	Piston
26	1C4184900	Piston key
28	7FU1078LO	Seal packing OS1100-85-9
29	1C2522	Valve end spring

30	1C2521	Return valve spring
31	1C2519	Return valve
32	1C4139500	Steel ball 4.5
33	7ORS4	O ring S4
34	1C4160600	Release valve
35	1C1022901	Cylinder
36	1C2610	Ram
37	1C1330	Ram return spring
38	1C13281	Delivery valve
39	1C1331	Delivery valve spring
40	1C13352	Spring guide
41	1C13292	Pump head seal
42	3P1044	Magnet filter
43	1C2609	Ball bearing 609
44	1C2525	Bearing guide
45	1C2534	Needle bearing
46	1C2525	Bearing guide
47	1C2526	Snap ring H35
48	1C4165800	Pump case packing
49	1C1021301	Pump case
50	1C1305	Seal washer WF10
51	1C1304	Cap bolt M10x15
52	7GW0006	Teethed washer M6
53	7CB06055	Cap bolt M6x55
54	1C2542	Oil seal SC20-35-8
55	1C1941	Ball bearing 6004VV
56	7312435	Fan cover
57	7360406F	Armature
58	1C2612J	Ball bearing 62002RU

59	7340358F	Stator coil
60	7312449	Motor housing
61	7984271	Tapping screw D5x75
62	7SW0005	P. Washer M5
63	7CB05045	Cap bolt M5x45
64	7SS05008	Cap bolt M5x8
65	7312434	Bearing bush
66	7980487	Brush holder
67	1C2612A	Carbon brush
68	7940540	Brush cap
69	7981866	Handle A
70	7981867	Handle B
71	7990082	Support
72	1C1961B	Switch
73	7994273	Condenser
74	1C4160400	Handle stay
75	1C1961I	Cord armor
76	7990940	Distance piece
77	7CB06035	Cap bolt M6x35
78	7FCB06025	Flange socket M6x25
79	4V0001V	Cord set
80	7956636	Tapping screw D4x25
81	1C4156001	Tube
82	7PW0006	P. Washer M6
83	7SW0005	S. Washer M5
84	7GW0008	Teethed washer M8
85	7SW0008	S. Washer M8
86	7CB08030	Cap bolt M8x16

DCC-1618HL

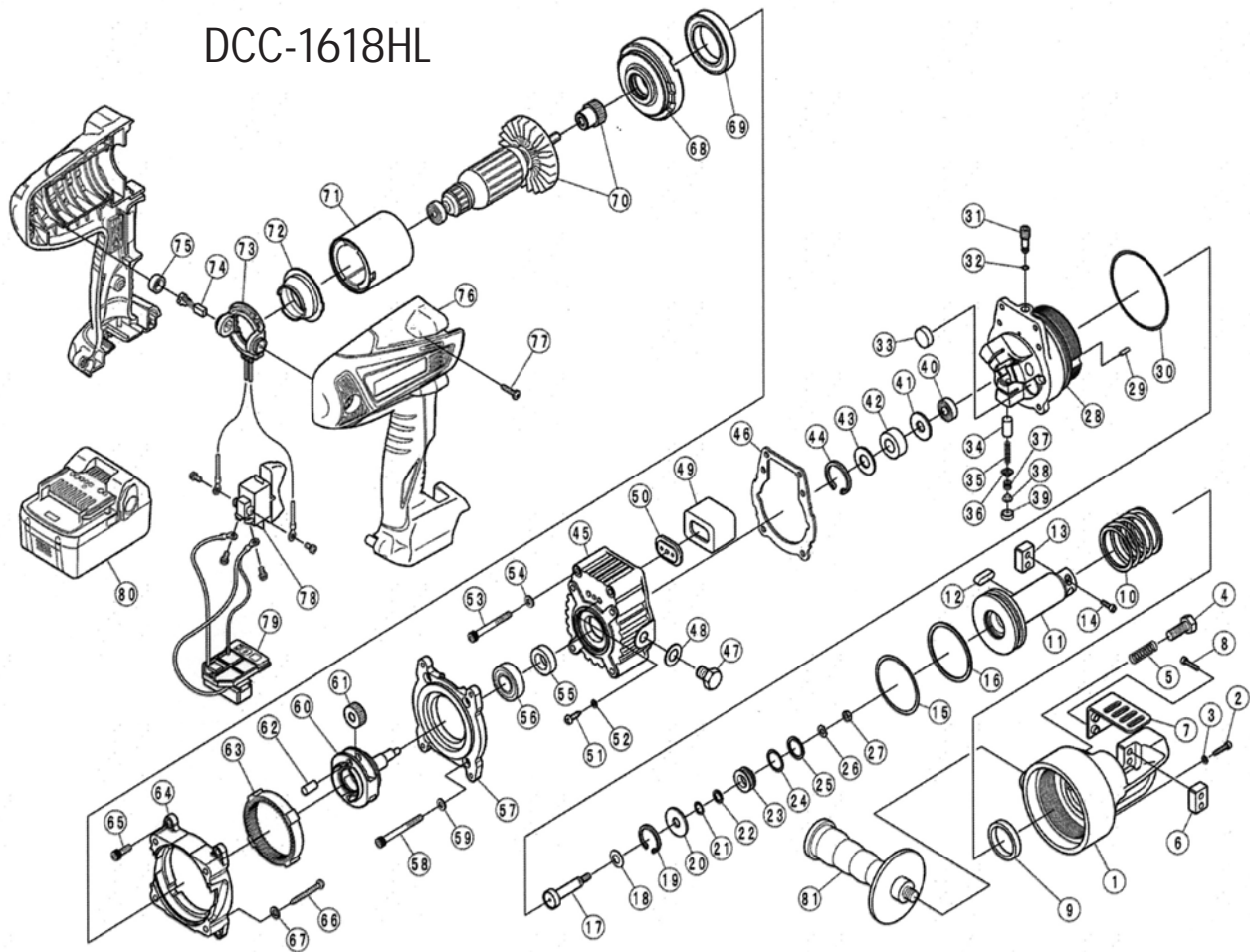

No.	Part No.	Part Name
1	1C2059501	HOUSING
2	70805035	CAP SOLT M5X35
3	7WF05	SEAL WASHER WF5
4	7B10025T11	STOPPER BOLT 10X25
5	104079400	LOCK SPRING
6	10L003	CUTTER BLOCK NO. 13L
7	104199500	CUTTER GUARD
8	708205022	CAP SOLT WITH WASHER
9	7USI26	USIPACKING
10	104139602	RETURN SPRING
11	103097800	PISTON
12	7K0606023R2H	PISTON KEY
13	10L003	CUTTER BLOCK NO. 13L
14	708205015	CAP BOLT WITH WASHER
15	70RP49RF	O RING P49RF
16	7BRP49B	BACK UP RING P49
17	104138501	RETURN VALVE
18	7BW008	DISK SPRING 8
19	7SRH026	SNAP RING H26
20	1084104002	GUIDE CLAMP
21	7SPN08	SPNC PACKING SPNCB
22	7BRP8B	BACK UP RING PBT2
23	104152300	RETURN VALVE GUIDE
24	70RP16	ORINGP16
25	7BRP16B	BACK UP RING P16T2
26	SPW005	PLATE WASHER S5
27	7NU005	U NUT 5

28	102044601	CYLINDER
29	7SP03010	SPRING PIN 3X10
30	70RG70RF	O RING G70RF
31	104196500	RELEASE VALVE
32	70RS4	O RING S4
33	3P1044	MAGNET FILTER
34	104103200	RAM
35	104197100	REM RETURN SPRING
36	10197301	DELIVERY VALVE
37	101331	DELIVERY VALVE SPRING
38	1013352	SPRING GUIDE
39	1013292	PUMP HEAD SEAL
40	7635	BALL BEARING
41	104103000	BEARING GUIDE
42	7RNF48151C	NEEDLE BEARING
43	104137200	BEARING GUIDE 2
44	7SRH020	SNAP RING H20
45	102044700	PUMP CASE
46	104143403	PUMP CASE PACKING
47	7810010	BOLT 10X10
48	7WF10	SEAL WASHER WF10
49	104137300	AIR BAG
50	104137400	AIR BAG NUT
51	7NT04012	TAPPING SCREW 4X12
52	7SW004	SPRING WASHER M4
53	70805045	CAP SOLT M5X45
54	7GW005	WASHER M5
55	75012257	OIL SEAL

56	76901ZZ	BALL BEARING 6901ZZ
57	103130300	DISTANCE PIECE P
58	70805050	CAP SOLT M5X50
59	7GW005	WASHER M5
60	103130100	CAM SHAFT
61	104256200	IDLE GEAR 22
62	7HTK333806B	NEEDLE ROLLER A
63	7HTK333807B	RING GEAR
64	103130200	DISTANCE PIECE M
65	708205015	CAP SOLT WITH WASHER
66	7NT05060	TAPPING SCREW 5X60
67	7SW005	SPRING WASHER M5
68	104255900	INNER COVER
69	7HTK334310B	BALL BEARING 61907GB
70	1C4256100AS	ARMATURE ASSY
71	7HTK333796B	MAGNET
72	7HTK333797B	DUST GUARD FIN
73	7HTK334311B	BRUSH HOLDER
74	7HTK999100B	CARBON BRUSH SET
75	7HTK319847B	BRUSH CAP
76	103130000	MOTOR HOUSING SET
77	7HTK3016538	FLANGE TAPPING SCREW 4X20
78	7HTK333795B	SWITCH
79	7HTK334313B	TERMINAL PIECE SET
80	7BSL1830	BATTERY PACK BSL1830
81	1C1627	SIDE HANDLE

DCC-2018HL

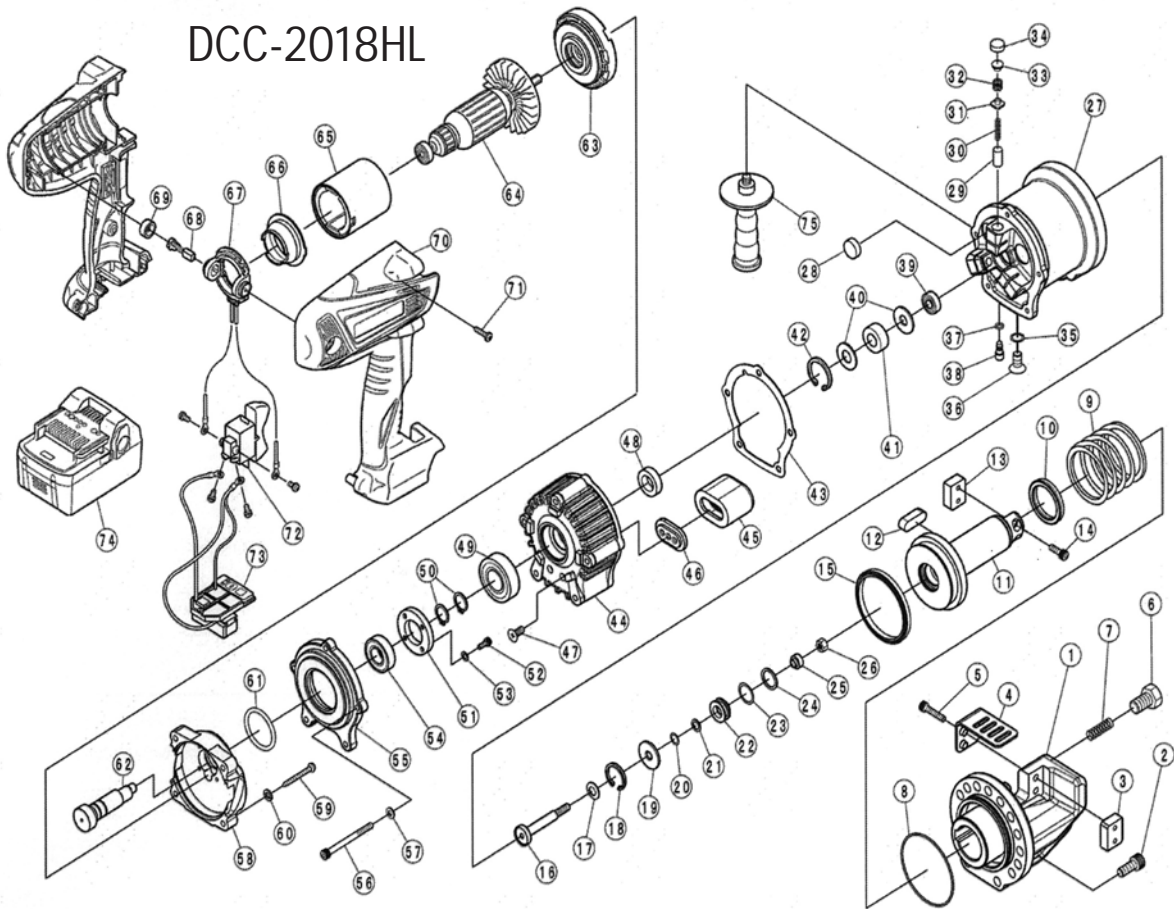

No.	Part No.	Part Name
1	1C2066401	HOUSING
2	70608020	CAP BOLT M8X20
3	101610	CUTTER BLOCK NO. 0
4	104199700	CUTTER GUARD
5	706205025	CAP BOLT WITH WASHER
6	7B12020T11	STOPPER BOLT 12X20
7	104079400	LOCK SPRING
8	70RS67	O RING S67
9	1016052	RETURN SPRING
10	7SKY32	SKY PACKING 32-42-6
11	103123600	PISTON
12	7K100829.5R2	PISTON KEY
13	101610	CUTTER BLOCK NO. 0
14	706205015	CAP BOLT WITH WASHER
15	101604	SEAL PACKING
16	1CM20181	RETURN VALVE
17	7BW008	DISK SPRING 8
18	7SRH026	SNAP RING H26
19	1064104002	GUIDE CLAMP
20	7BRP8B	BACK UP RING P8T2
21	7SPN08	SPNC PACKING
22	1016081	RETURN VALVE GUIDE
23	7BRP16B	BACK UP RING P16T2
24	70RP16	O RING P16
25	104242500	RETURN VALVE COL-LAR

26	7NU006	U NUT 6
27	1C2066500	CYLINDER
28	3P1044	MAGNET FILTER
29	101327	RAM
30	101330	RAM RETURN SPRING
31	1013281	DELIVERY VALVE
32	101331	DELIVERY VALVE SPRING
33	1013352	SPRING GUIDE
34	1C13292	PUMP HEAD SEAL
35	70RP10	O RING P10
36	75608012	FLAT HEAD BOLT 8X12
37	70RS4	O RING S4
38	104160601	RELEASE VALVE
39	7608M03	BALL BEARING 608MC3
40	1C1325	BEARING GUIDE
41	712NQ2410.A	NEEDLE BEARING
42	7SRH027	SNAP RING H27
43	104079300	PUMP CASE PACKING
44	102025800	PUMP CASE
45	104078900	AIR BAG
46	104079000	AIR BAG NUT
47	7ST06012B1	TAPPING SCREW B1 6X12
48	75015257	OIL SEAL
49	76002VV	BALL BEARING 6002VV
50	7SRS015	SNAP RING S15
51	3AP4230600	WASHER

52	706504010	CAP BOLTS 4X10
53	7GW004	WASHER M4
54	76902ZZ	BALL BEARING 6902ZZ
55	103129900	DISTANCE PIECE P
56	70605060	CAP BOLT M5X60
57	7GW005	WASHER M5
58	1C3129800	DISTANCE PIECE M
59	7NT05030	TAPPING SCREW 5X30
60	7SW005	SPRING WASHER M5
61	7JAS020371ATF	O RING JAS02037
62	103129700	CAM SHAFT
63	7HTK333808B	INNER COVER
64	7HTK360922B	ARMATURE ASSY
65	7HTK333796B	MAGNET
66	7HTK333797B	DUST GUARD FIN
67	7HTK334311B	BRUSH HOLDER
68	7HTK999100B	CARBON BRUSH SET
69	7HTK319847B	BRUSH CAP
70	1C3130000	MOTOR HOUSING SET
71	7HTK3016538	FLANGE TAPPING SCREW 4X20
72	7HTK333795B	SWITCH
73	7HTK334313B	TERMINAL PIECE SET
74	7BSL1830	BATTERY PACK BSL1830
75	1C1627	SIDE HANDLE



BN PRODUCTS-USA, LLC.
Tools For The Professional Craftsman

REBAR TOOLS

THE INDUSTRY STANDARD

For over 30 years, we have been making products that will save you money, make you money and add value to your bottom line.

The Original Portable Rebar Cutters

With as many as eight different models that cut #3 all the way up to #10 rebar, these electric-hydraulic tools have consistently proved their worth in the field or in the shop year after year.



Easy On-Site Rebar Bending Solutions

We have engineered seven basic models that can fit most job-site requirements. These electro-mechanical tools have been designed to be work-horses out in the field.



The DBC-16H Portable #5 Rebar Bender/Cutter



This combination tool provides jobsite cutting and bending all in one tool. The unique design provides the operator the ability to work rebar for in-place or stationary fabrication applications. The DBC-16H can easily bend #5 grade 60 rebar 180°.

Voted the Most Innovative Tool at the World of Concrete Show

The BNCE-20 Cutting Edge Power Saw cleanly cuts rebar, all-thread rod and much more. It produces virtually no sparks or burrs and it is versatile enough to flush cut up to 7/8" steel rod economically - Up to 500 cuts on #5 - 60 grade rebar per \$25 retail blade.



The Best Manual Rebar Bender/Cutters

The MBC-16B incorporates a longer handle, an adjustable roller cam shaft, replaceable cutting jaws, a sturdy frame mounted to a wood board, a comfortable non-slip handle grip and a convenient lifting chain. No wonder it is the pick of most professional contractors.



BN PRODUCTS-USA, LLC.

The industry leader for rebar tools used by professional contractors around the world.
Wickenburg, Arizona 85390
(800) 992-3833 • mail@bnproducts.com

Notes:

